

Gardner
Denver

HIGH PRESSURE SOLUTIONS

Oil-Free Compressors for PET Bottle Blowing





Gardner Denver High Pressure Compressors

With the GD Compressors brands, we have grown into one of the world's most respected organizations within high compression technology. We build our future with total respect for our unique heritage and by demonstrating our passion for our global brands through technology leadership. Our team is professional, customer focused and leaders in their field ensuring you are equipped with exactly the right high pressure solution.

PET Bottle Blowing

We have over 40 years of experience in supplying oil free reciprocating compressors for the PET bottle blowing market and have supplied compressors for some of the largest PET bottling plants in the world today. Due to our vast experience, Belliss & Morcom have become the recognized industry leaders, where customers globally enjoy greater productivity and lower operating costs. Belliss & Morcom compressors set the standard for reliable, efficient and cost-effective PET bottle blowing operations.

Belliss & Morcom Product Timeline 1852 to Present

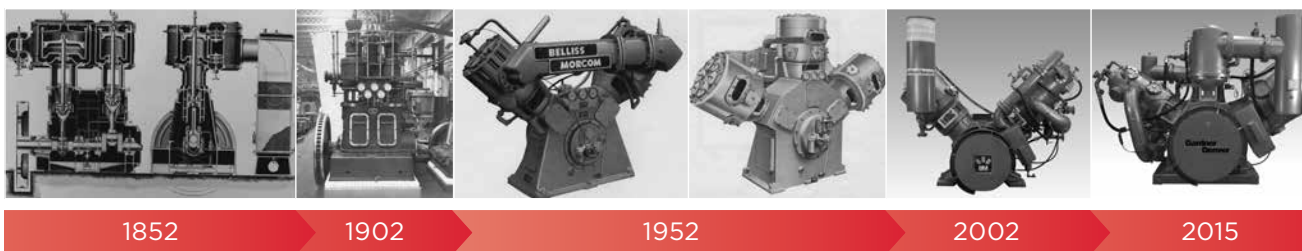

Performance. Reliability. Durability.

Gardner Denver Belliss & Morcom have the ability to understand our customer's specific requirements and are committed to ensuring we provide intelligent solutions that meet your ultimate needs.

Lowest Cost of Ownership

Our standard compressor units are all designed to seamlessly combine with our enhanced products and flexible package options, meaning the Gardner Denver Belliss & Morcom brand of products can create a lowest cost of ownership compressor solution. With the highest efficiency motors at 97.1% and the latest in extended life materials technology, both the VH and WH range continue to out perform all other 40 barg oil free compressors in the PET industry. Maintenance costs are also kept to a minimum due to our unique shaftless motor, with no belts or bearings there are fewer parts to maintain, which can eliminate unscheduled downtime.

Low Power Consumption - High on Efficiency

The Gardner Denver Belliss & Morcom product range of oil free compressors have a proven track record for being the most energy efficient compressors available for PET applications. With each compressor driven by our EEF compliant water cooled motor, our 3 stage oil free compressor is proven to be the most power efficient design concept for a 40 barg PET compressor.

Small Compressor Footprint

Where space is at a premium, the Belliss & Morcom range of oil free compressors offer a neatly arranged compressor system in the smallest available footprint. With no specialist foundations required, our compressor systems are easily installed and fully operational in the shortest possible time scale.

Balanced Operation

All Belliss & Morcom compressors are dynamically balanced, therefore removing the need for any special and expensive structural foundations, the compressor room floor only requires to carry the static weight of the compressor.

Maximum Oil Free Air Quality

With absolutely no risk of contamination, Belliss & Morcom compression technology delivers the highest quality, oil free compressed air meaning no possibility of oil contamination in your process up to ISO 8573 class 0. The intrinsically oil free air produced by a Belliss & Morcom compressor meets all air quality standards including Pure Air - ISO 8573-1.



BellissMorcom

VH Oil-Free Range

The Belliss & Morcom VH range of compressors offers a neatly arranged compressor system which provides maximum oil free air capacity in the smallest available footprint.

- 420-1,500 m³/hour at 40 barg
- 90-260 kW Direct Zero-Drive-Loss 'Shaftless' Motor
- Oil-Free
- Water Cooled
- 3 Stages
- Capacity Control: 0-100%
- Variable Speed Capacity Range from 50-100%
- Fully Balanced Operation



VH PET Range Specifications

CAPACITY @ 40 BARG

BELLISS MODEL	50 HZ					60 HZ				
	CAPACITY FAD m ³ /hr / cfm	DELIVERY PRESSURE barg / psi(g)	SPEED rpm	SHAFT POWER kW / HP	MOTOR POWER kW / HP	CAPACITY FAD m ³ /hr / cfm	DELIVERY PRESSURE barg / psi(g)	SPEED rpm	SHAFT POWER kW / HP	MOTOR POWER kW / HP
VH7	420 / 247	40 / 580	735	75 / 100	90 / 125	406 / 247	40 / 580	710	72 / 97	90 / 125
VH9	580 / 341	40 / 580	985	101 / 135	110 / 150	518 / 304	40 / 580	880	90 / 120	110 / 150
VH12	729 / 431	40 / 580	585	116 / 155	120 / 200	729 / 431	40 / 580	585	124 / 166	150 / 200
VH15	916 / 539	40 / 580	735	146 / 196	150 / 235	885 / 521	40 / 580	710	150 / 202	175 / 235
VH18	1116 / 657	40 / 580	585	185 / 248	185 / 2820	1116 / 657	40 / 580	585	192 / 256	210 / 280
VH21	1402 / 825	40 / 580	735	227 / 305	235 / 350	1354 / 797	40 / 580	710	227 / 304	260 / 350
VH25	1500 / 882	40 / 580	735	242 / 325	260 / 350	1449 / 853	40 / 580	710	242 / 323	260 / 350

CAPACITY @ 30 BARG

BELLISS MODEL	50 HZ DATA					60 HZ DATA				
	CAPACITY FAD m ³ /hr / cfm	DELIVERY PRESSURE barg / psi(g)	SPEED rpm	SHAFT POWER kW / HP	MOTOR POWER kW / HP	CAPACITY FAD m ³ /hr / cfm	DELIVERY PRESSURE barg / psi(g)	SPEED rpm	SHAFT POWER kW / HP	MOTOR POWER kW / HP
VH7	431 / 254	30 / 435	735	69 / 92	90 / 125	417 / 245	30 / 435	710	67 / 89	90 / 125
VH9	593 / 349	30 / 435	985	93 / 124	110 / 150	530 / 312	30 / 435	880	83 / 111	110 / 150
VH12	743 / 437	30 / 435	585	112 / 150	132 / 200	743 / 437	30 / 435	585	112 / 150	150 / 200
VH15	933 / 549	30 / 435	735	141 / 188	160 / 235	901 / 530	30 / 435	710	136 / 182	175 / 235
VH18	1122 / 660	30 / 435	585	177 / 237	210 / 280	1122 / 660	30 / 435	585	177 / 237	210 / 280
VH21	1410 / 829	30 / 435	735	221 / 296	260 / 350	1362 / 801	30 / 435	710	213 / 286	260 / 350
VH25	1509 / 887	30 / 435	735	248 / 332	260 / 350	1457 / 857	30 / 435	710	240 / 321	260 / 350

WH Oil-Free Range

The Belliss & Morcom WH range of compressors offers higher volumes of oil free air utilizing energy efficient equipment and components. The double acting design provides greater flexibility in capacity control and lower power consumption.

Our unique design includes a three step capacity control with the piston compressing air on the up stroke as well as the down. This type of capacity control allows our customers to save energy and money.

Our inclined cylinder arrangement optimizes balance and extends component life, reducing maintenance costs and minimizing floor space.

- 1,680–3,200 m³/hour at 40 barg
- 280–550 kW Direct Zero-Drive-Loss ‘Shaftless’ Motor
- Oil-Free
- Water-Cooled
- 3 Stages
- Capacity Control: 0% / 50% / 100%
- Variable Speed Capacity Range from 30–100%
- Fully Balanced Operation



WH PET Range Specifications

CAPACITY @ 40 BARG

BELLISS MODEL	50 HZ					60 HZ				
	CAPACITY FAD m ³ /hr / cfm	DELIVERY PRESSURE barg / psi(g)	SPEED rpm	SHAFT POWER kW / HP	MOTOR POWER kW / HP	CAPACITY FAD m ³ /hr / cfm	DELIVERY PRESSURE barg / psi(g)	SPEED rpm	SHAFT POWER kW / HP	MOTOR POWER kW / HP
WH28	1680 / 988	40 / 580	735	258 / 346	260 / 375	1623 / 955	40 / 580	710	256 / 343	280 / 375
WH29	1800 / 1058	40 / 580	735	270 / 362	270 / 435	1739 / 1024	40 / 580	710	277 / 371	325 / 435
WH35	2120 / 1248	40 / 580	735	330 / 442	350 / 483	2045 / 1204	40 / 580	710	330 / 443	348 / 467
WH40	2300 / 1354	40 / 580	735	350 / 470	350 / 535	2222 / 1308	40 / 580	710	355 / 476	385 / 535
WH45	2700 / 1589	40 / 580	735	437 / 585	450 / 603	2608 / 1535	40 / 580	710	422 / 565	450 / 603
WH50	3200 / 1883	40 / 580	735	505 / 677	505 / 737	3091 / 1819	40 / 580	710	500 / 670	550 / 737

CAPACITY @ 30 BARG

BELLISS MODEL	50 HZ DATA					60 HZ DATA				
	CAPACITY FAD m ³ /hr / cfm	DELIVERY PRESSURE barg / psi(g)	SPEED rpm	SHAFT POWER kW / HP	MOTOR POWER kW / HP	CAPACITY FAD m ³ /hr / cfm	DELIVERY PRESSURE barg / psi(g)	SPEED rpm	SHAFT POWER kW / HP	MOTOR POWER kW / HP
WH28	1693 / 995	30 / 435	735	242 / 324	280 / 375	1635 / 962	30 / 435	710	234 / 313	280 / 375
WH29	1817 / 1068	30 / 435	735	262 / 351	325 / 435	1755 / 1032	30 / 435	710	253 / 339	325 / 435
WH35	2145 / 1262	40 / 580	735	316 / 424	333 / 447	2070 / 1218	40 / 580	710	305 / 409	322 / 432
WH40	2313 / 1360	30 / 435	735	337 / 452	385 / 535	2234 / 1314	30 / 435	710	326 / 436	350 / 535
WH45	2716 / 1597	30 / 435	735	412 / 552	450 / 603	2624 / 1543	30 / 435	710	398 / 533	450 / 603
WH50	3229 / 1899	30 / 435	735	463 / 619	550 / 737	3119 / 1834	30 / 435	710	447 / 598	550 / 737

What makes the Belliss & Morcom range **unique?**

LOW POWER CONSUMPTION

Use of energy efficient equipment ensuring lower operating costs

SMALL COMPACT FOOTPRINT

Reduction in space requirements leads to cost savings for floor space

DIRECT DRIVE SHAFTLESS MOTOR

Reduces power absorbed and eliminates any belt drive losses

SIMPLE INSTALLATION

Compact skid packages thus reducing installation costs

BALANCED OPERATION

Dynamically balanced removing the need for any special foundations

SINGLE COMPRESSOR BLOCK

One single 3 stage block resulting in the most efficient air solution

HALF LOAD CAPABILITY

Reduced power at partial load conditions for the WH range

LOW MAINTENANCE

Only one major annual service required

ROBUST CONSTRUCTION

Ensures continuous 24/7 operation maintaining production output

HIGH OPERATING EFFICIENCY

Results in maximum compressor and plant performance

HIGH QUALITY OIL FREE AIR

Guaranteed clean dry air to ISO 8573.1 Class 1.2.4

SINGLE TURNKEY PARTNERS

A single source for both PET blowing and utility air requirements

GLOBAL SUPPLY & LOCAL SUPPORT

Dedicated sales and service centres protect your investments

VH and WH PET range dimensions

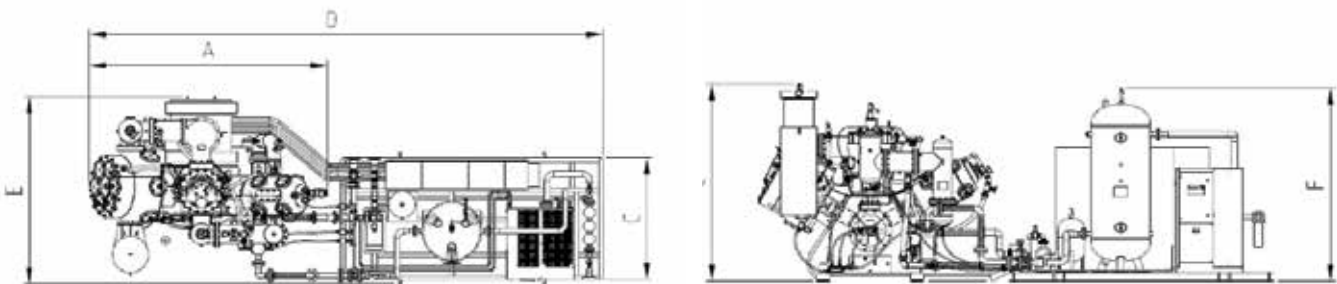

MODEL	INSTALLED MIN AREA*	A (MM)	B (MM)	C (MM)	D (MM)	E (MM)	F (MM)	WEIGHT COMP. (KG)	WEIGHT SKID (KG)
VH7	7750 x 4600	2350	2260	1980	5770	2100	2695	3875	2350
VH9	7750 x 4600	2350	2260	1980	5770	2100	2695	3875	2350
VH12	8650 x 4600	2950	2300	2645	6670	2100	2695	5160	2400
VH15	8650 x 4600	2950	2300	2645	6670	2100	2695	5160	2400
VH18	8750 x 4600	3025	2370	2600	6750	2100	2695	6345	2500
VH21	8750 x 4600	3025	2370	2600	6750	2100	2695	6345	2500
VH25	7800 x 4300	3025	2370	2600	6900	2100	2740	6800	2600
WH28	9300 x 4900	3275	2980	2950	7350	2100	2740	9900	2900
WH29	9300 x 4900	3275	2980	2950	7350	2100	2740	9900	2900
WH35	9950 x 4900	3500	3110	3190	7950	2100	2740	10410	3000
WH40	9950 x 4900	3500	3110	3190	7950	2100	2740	10410	3000
WH45	9950 x 4900	3400	3150	3190	7950	2100	3210	11500	3600
WH50	10500 x 4900	4000	3150	3315	9000	2100	3210	12000	3600

* installed minimum area required for Ancillary Skid package - (indication only - sizes differ depending on application)

VH & WH Range

The VH & WH Ranges are also available as complete packages including all essential ancillary items such as starter control panels with PLC logic systems, energy efficient motors, air dryer, air receiver, filters and optional cooling systems to suit all site conditions.

Ancillary Skid Options

All our ranges can be installed as floor mounted compressors with all ancillary equipment fixed on a baseplate, complete with all interconnecting pipework and electrical wiring, with options for acoustic enclosures.

Loose Equipment

All equipment can be supplied as loose items with a 'kit' of interconnecting parts that just require final connections on site.



Gardner Denver Full Turnkey Installation, Commissioning & Training

Correct installation is essential in providing long-term compressor reliability. Gardner Denver provide full turnkey solutions from initial site surveys through to design, installation and final commissioning.

Our fully qualified engineers assess all critical factors such as location, radiated heat, noise and air inlet conditions to ensure the complete compressor installation functions reliably whatever the environment.



Enhanced Products Designed to Monitor, Control & Save

The Most Efficient Solution for PET Bottle Blowing Intelligent Multi-Compressor Systems

The AirPET compressor control system is designed to give a better and more accurate overall control of the air pressure on a multi-compressor system than the conventional methods.

Air Recovery

The Air Recovery System is designed to accommodate a returned pressure from the Blow Moulding machines that can be 'recycled' back through the compressor.

- Reduction in compressor energy consumption
- Easily installed to existing installation
- Can be used to supplement LP air requirements

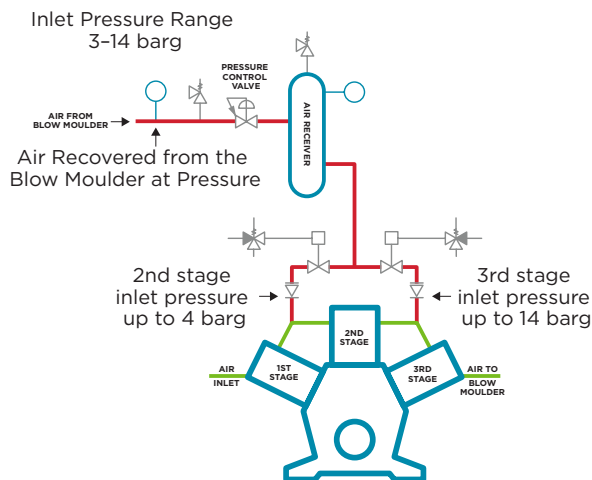

Heat Recovery

Belliss & Morcom have developed a Heat Recovery System to work with the PET compressor. The PET compressors use cooling water to cool the compressor and the compressed air. The water once heated through the compressor will then need to be cooled through the compressor cooling tower.

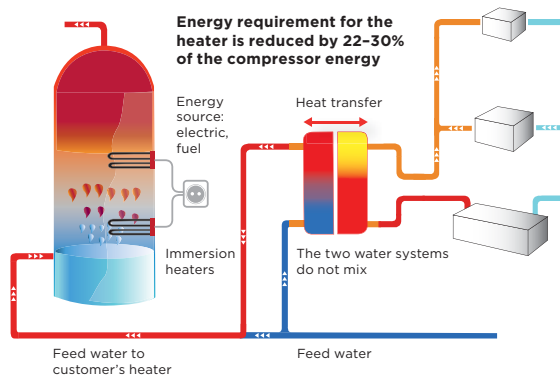

The compressor cooling system can be modified to provide water at around 80°C to pre-heat the customers own feed water to their heating systems (water or steam) and thus reduce their energy load through the water/steam heater. Savings are typically 22-30% of the compressor motor rating kW.

FEATURES

- Powerful trending and logging facilities to implement effective plant management
- Main plant networked if required
- Can monitor other items of equipment and plant, giving a common database to assist with effective plant management
- Can monitor low pressure compressors if required
- A broadband connection will allow remote monitoring and assistance
- Proven Technology with International hardware and software support
- Can monitor up to 30 compressors of any make, model or combination

BENEFITS

- Reduces energy costs by reducing compressor off-load time
- Provides live energy usage, energy costs and live CO₂ emissions data
- AirPRESSURE control of the main line to within +/- 0.5 barg
- AirPREDICT allows a compressor to be online smoothly before the demand is required
- AirSAVE allows the compressor to be switched off, or at low pressure, at weekends or on non-productive shifts
- Ensures optimum compressor usage and improved compressor performance
- Predictive planned maintenance and downtime management

Variable Speed Drives

- Reduced energy costs
- Variable capacity control: 30–100%
- Reduced motor starting current (within the FLC of the motor)
- Improved efficiency and power factor
- Extended component life
- Accurate and repeatable pressure control

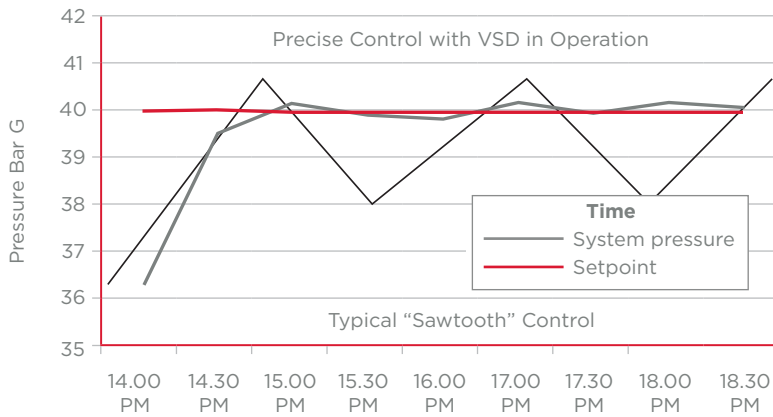

AirPet System

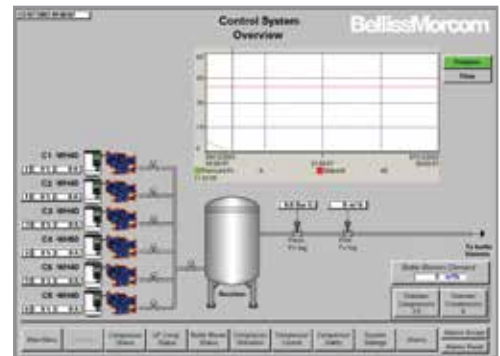
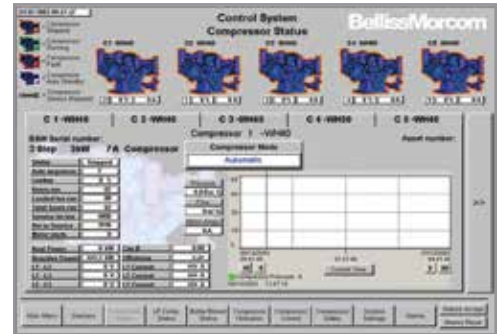

High Efficiency Water-Cooled Motor

It is widely accepted within industry today that the running of motors and drives account for a large percentage of energy usage. Using the right energy efficient motors will help lower your carbon footprint as well as your energy bills. With this in mind Belliss & Morcom developed a unique water cooled shaftless motor, which makes our compressor systems the most energy efficient on the market.

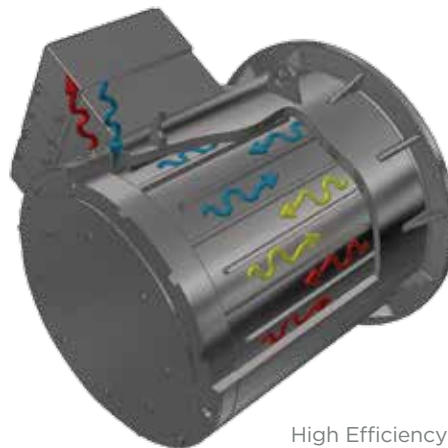

High Efficiency Water Cooled Motor

BENEFITS

- Lower electricity consumption
- Higher efficiency of 97.1%
- Lower CO₂ emissions
- Suitable for variable speed drive
- IP56 construction, suitable for all operating environments
- 100% reduction in radiated heat
- Low noise specification
- Maintenance free
- Connects direct to the existing compressor cooling circuit
- The environmentally friendly 'green' option
- Specifically designed for the global drinks industry

Energy Audits

In order to reduce energy costs and CO₂ emissions, Belliss & Morcom offer audits tailored to suit your specific needs by our team of dedicated experts.

Please contact us for more details.



Enhanced Products Designed to Monitor, Control & Save

Protect Your Investment with Confidence

To ensure optimum compressor performance and reliability, only one specification of spare part should be used: the original one. Belliss & Morcom guarantee every spare part ordered.

Comprehensive Parts Stock Holding

Stock holding around the world means parts can be dispatched from our support centres within hours of order.

Convenient Service Packs

Service packs and kits provide all the necessary components to carry out field services and repairs efficiently.

Aftermarket Products & Services

- Fixed Cost Preventative Maintenance
- Compressor and Component Refurbishment
- Enhanced Product Upgrades
- On Site Commissioning and Training
- Full Turn Key Installations
- Unrivalled Product & Technical Support

Our Day-to-Day Commitment to You and Your Business

- 24 Hours a Day, 365 Days a Year Support
- Extensive Spare Parts Stock Holding
- Experienced Local Product and Technical Support

Plus the added advantage of the best technical advice and support available in the market place today.



How Does it Work?

- Unlimited protection programme for the life of your compressor(s)
- You will be fully budgeted against any unforeseen or unscheduled breakdown and failures
- It gives you peace of mind through maximized productivity and lowered costs

FEATURES

- A simple, straightforward agreement – no hidden extras, no small print
- Unlimited operating hours on the compressor
- 100% original spare parts with proven performance and reliability
- Scheduled maintenance carried out by factory-trained technicians
- Only one service required each year, depending on model, increasing compressor availability

BENEFITS

- Parts stocked locally to minimise downtime
- Interactive and proactive compressor monitoring
- Elimination of unexpected repair costs
- Long term reliability and improved operational visibility, with free user-friendly expert advice

Gardner
Denver
AFTERMARKET

The leader in every market we serve
by continuously improving all business processes
with a focus on innovation and velocity

**Gardner
Denver**[®]

Gardner Denver, Inc.

1800 Gardner Expressway
Quincy, IL 62305
866-440-6241

www.gardnerdenverproducts.com



©2015 Gardner Denver, Inc. Printed in U.S.A.
GDHP-OF-PET 1st Ed. 9/15

 Please recycle after use.