

Installation, Operating & Maintenance Manual

(Original Instructions)

DRUM

**D9000
HOOK & CLAW
COMPRESSOR**

COOLER VERSION

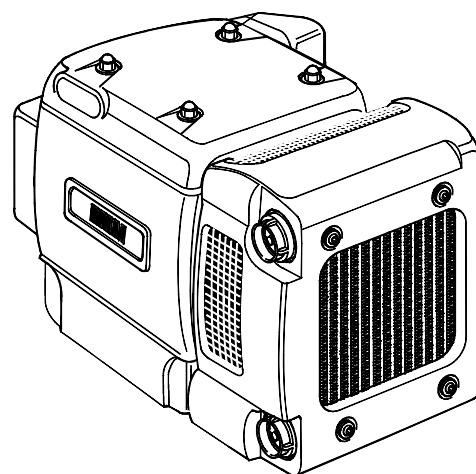

**4991510001
September 2013**

Contents

Chapter		Page
1	Health & Safety	
	Health & Safety Issues	2
2	General Description	3
2.1	Lifting and handling	4
2.2	General Dimensions	4
2.3	Radiator Mounting	5
2.4	Orientation	6
3	Installation	
3.1	Power requirements	7
3.2	Mounting	7
3.3	Cooler Radiator Mounting Instructions	8
3.4	Drive shaft alignment	9
3.5	Belt Drive.....	9/11
3.6	Discharge Air Cooler	12
3.7	Fan Mounting Arrangement.....	13
3.8	Removing the radiator cover	14
3.9	Removing the Drive Belts.....	14
3.10	Ancillary Equipment	15
4	Operating Instructions	
4.1	Safety	16
4.2	Starting the compressor.....	16
5	Maintenance Instructions	
5.1	Routine Maintenance.....	17
5.2	Draining the Gearcase Oil	17
5.3	Refilling and checking the oil level	18
5.4	Changing the Air Filter.....	18
5.5	Checking Relief Valve Operation	19
5.6	Greasing the Drive Shaft Bearing Caps	19

1. HEALTH AND SAFETY.

Read this manual carefully before starting an Installation.



Static electricity - Care should be taken to ensure, where necessary, that this and any other equipment is earthed in accordance with BS 5958 Part 1 1983 "Control of Undesirable static Electricity". (or other prevailing legislation in the country of operation). Powder / Air combinations are potentially explosive if not correctly earthed.



Drive line guards - Although care has been taken to avoid exposed rotating parts, It is the responsibility of the installer of the equipment to guard the exposed drive line in accordance with any prevailing safety legislation.



Never place your fingers into exposed inlet or outlet ports . If the rotors are turned, even by hand, serious injury could result.



A relief valve must be fitted in the outlet pipework to protect the compressor which must vent away from the operator. A notice, warning of the danger of burns from vented air must be fitted near the relief valve. The relief valve is NOT intended to protect the tank from over pressurisation (this is the responsibility of the tank manufacturer).

IN CASE OF FIRE



THIS PRODUCT CONTAINS
FLUROELASTOMER POLYMERS (VITON).



=



HYDROGEN
FLUORIDE

IMPORTANT Fluoroelastomer Polymer seals that have been exposed to temperatures of 300°C and above **MUST** not be handled with bare hands even when the seals have cooled down.



+



2. GENERAL DESCRIPTION

The D9000 compressor is an oil free hook and claw type compressor housed in an acoustic enclosure incorporating ancillary equipment. The unit is designed for the discharge of a wide range of bulk powders and granules. The after-cooler enables the discharge of more heat sensitive products.

The D9000 is supplied in either Left Hand or Right Hand configuration to suit space availability on the vehicle to which the unit is to be fitted (refer to Fig 3A).

A Belt Drive can be fitted to allow the D9000 to be driven from a PTO (Power Take Off) rotating in either direction. On applications where drive from a PTO is not available, Drum can supply hydraulic and electric drives or a remote diesel engine (for trailer or static applications) Consult your Drum agent for appropriate drives.

Fig 1 shows a typical D9000 system package which features as standard:

- GRP acoustic enclosure and mounting bracket.
- Integral inlet filter.
- Integral Inlet and Outlet silencers.
- Relief Valve mounted on the Outlet Silencer.
- Check (Non Return) Valve mounted to the outlet port.
- Flange Pack and Air Inlet Pipe Kit.

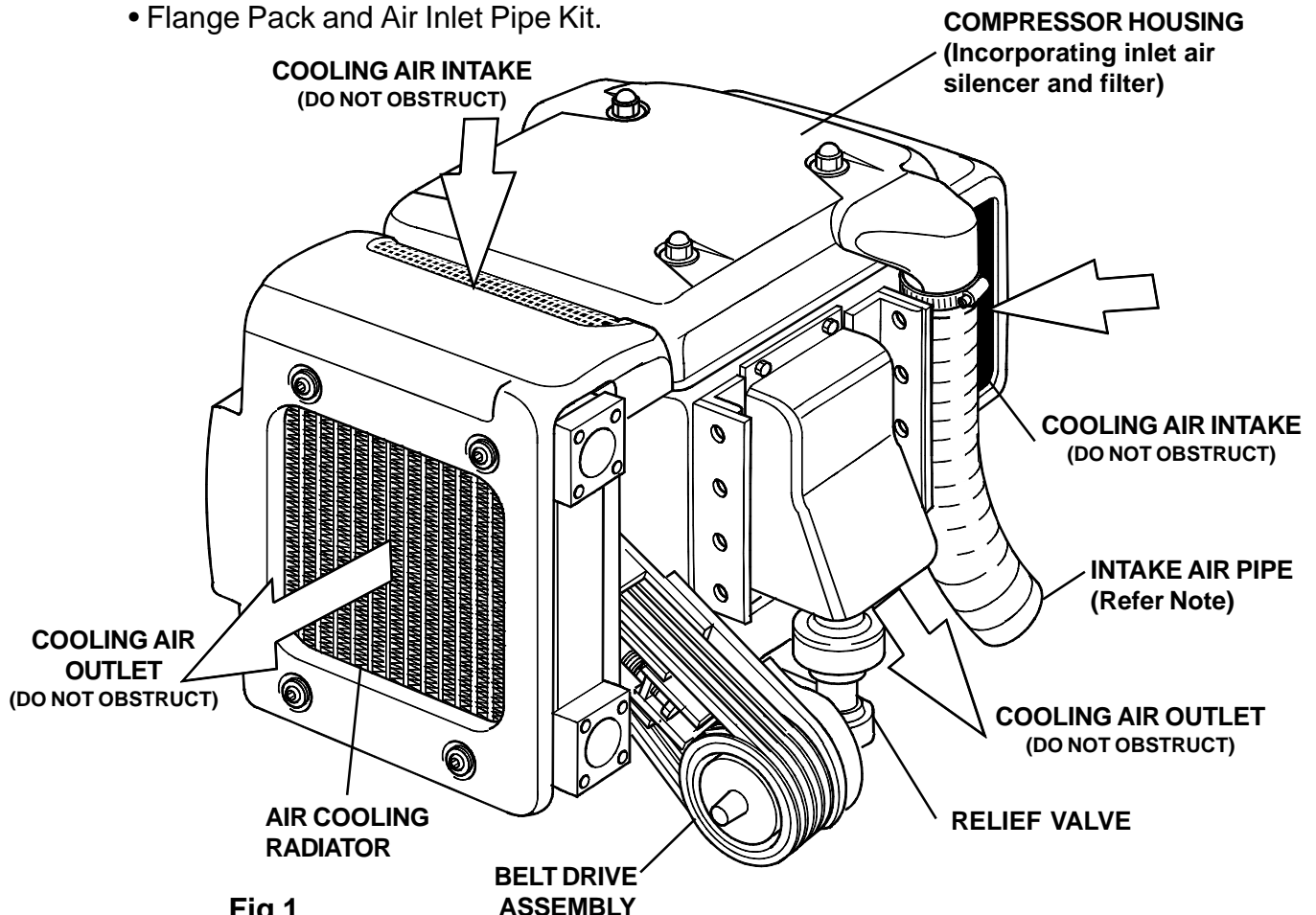

Fig 1
A TYPICAL INSTALLATION

Note: The free end of the Intake Air Pipe (89mm bore x 1metre long) must be located in a position where it will be free from the ingress of water and other contaminants and the air supply is cool and dry. An alternative method is to connect the pipe to the vehicle air inlet stack with a minimum of 100mm bore or fit a suitable rain hood. It is the responsibility of the installer to ensure that the connection to the vehicle stack meets the approval of the vehicle manufacturer.

2.1 Lifting and Handling

The D9000 unit weighs approx 360 Kg.

The D9000 unit should be lifted and installed onto the vehicle on its delivery pallet by fork lift truck.

CAUTION : LIFTING THE D9000 ON THE PALLET, WITH BELT ARM FITTED, WILL ALTER THE CENTRE OF GRAVITY AND MAY CAUSE THE UNIT TO OVERBALANCE

2.2 General Dimensions.

The overall dimensions of the D9000 are shown in fig 2.

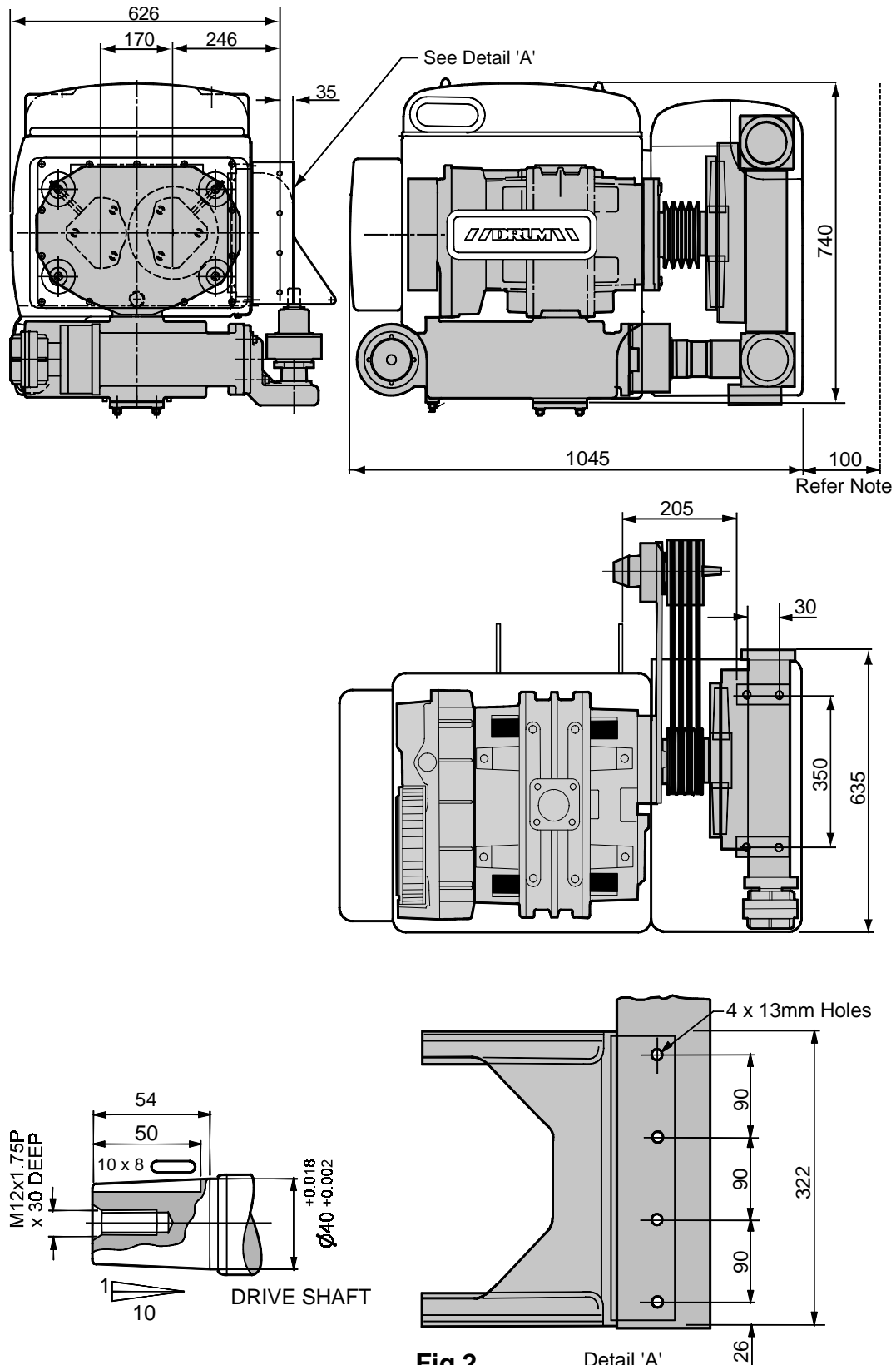
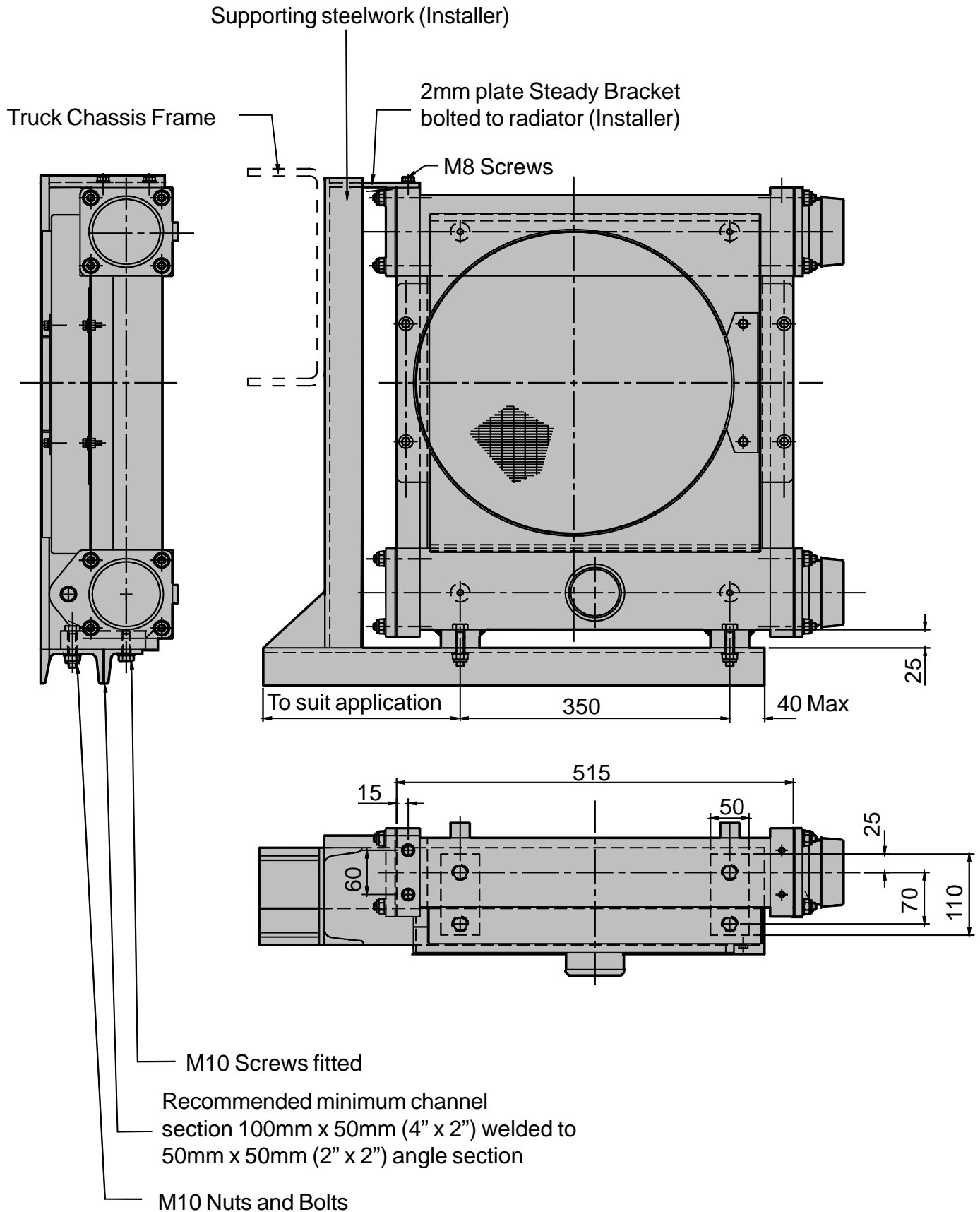

Fig 2
OVERALL DIMENSIONS

2.3 RADIATOR MOUNTING

Illustration below shows a 'typical' radiator mounting. Mounting details will vary according to differing applications. Support brackets and fasteners to be supplied by installer.



2.4 Orientation

The D9000 unit is supplied in either Left Hand or Right Hand formats, additionally, the units can be configured for Inboard or Outboard drive which refers to which shaft is being driven by the belt drive assembly. Fig 3A below shows the relationship between drive shaft, belt drive and vehicle chassis.

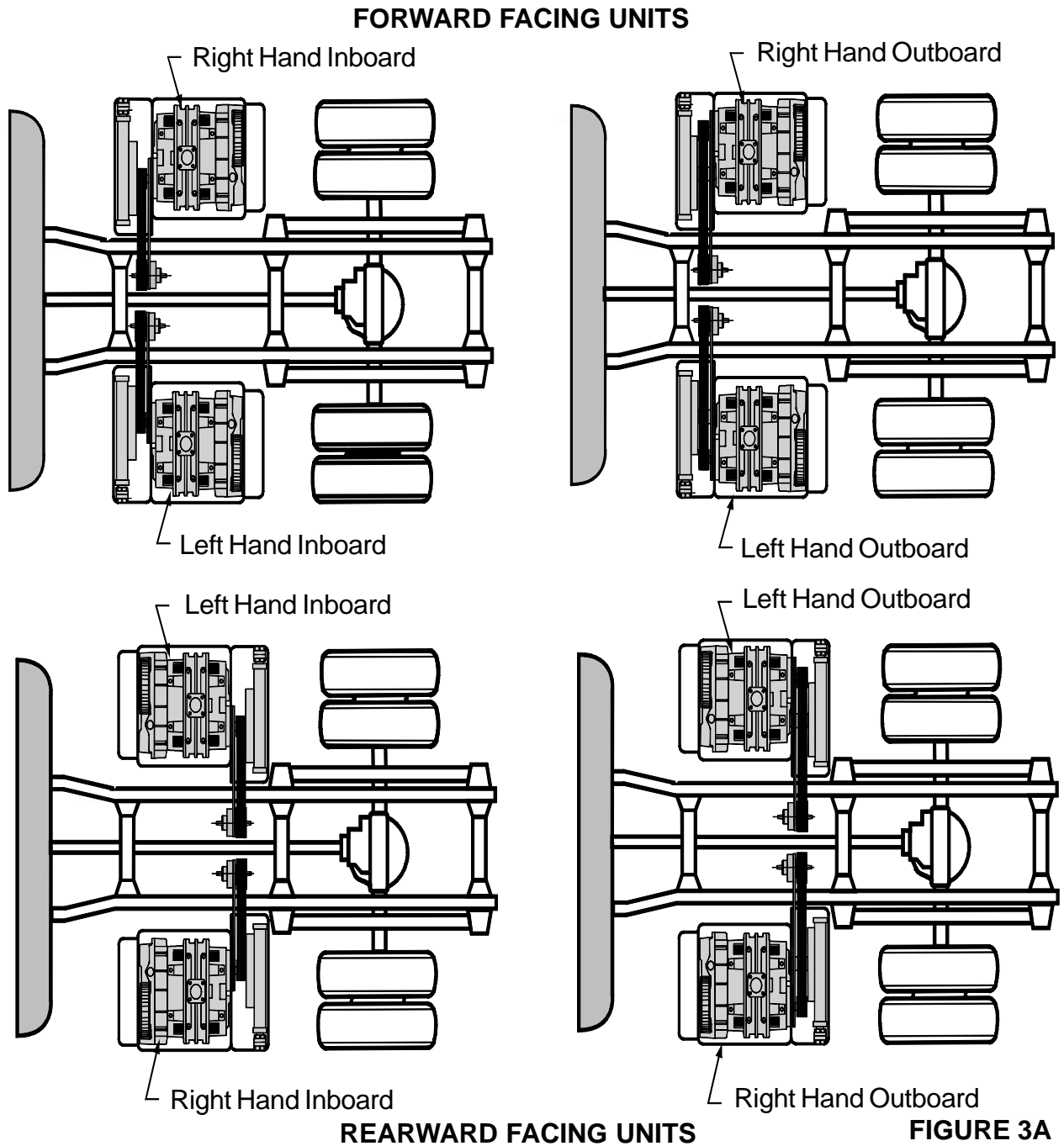

The D9000 unit can be driven from either of the 2 input shafts provided that the direction of rotation of the compressor shafts is maintained. Refer to the direction of rotation labels attached to the unit. (Fig 3B). The shaft rotation determines the selection of inboard or outboard drive configurations.

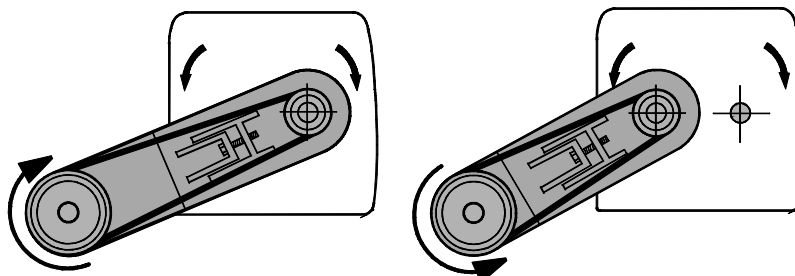

FIGURE 3B

3 INSTALLATION.

When installing the D9000 unit the following must be ensured:-

- The correct rotation of the D9000 rotors.
- The alignment of the D9000 drive and the vehicle PTO is within limits.
- That the air inlet to the unit is unobstructed.
- That the belt drive is installed correctly.

3.1 Power Requirements.

The vehicle Power Take Off (PTO) should be rated for the full power consumption of the D9000 i.e. 60 Kw. at 3000 rpm input shaft speed (190 Nm. torque at the compressor input shaft) = 340 Nm at propshaft for standard 1. 78:1 Belt Arm.

A belt drive capable of transmitting the required power and with a drive ratio to ensure an operating speed range of between 1800 and 3000 rpm for the D9000 is required. Consult your Drum agent for an appropriate belt drive.

3.2 Mounting.

Note : Please Refer to Section 2.1, Lifting and Handling.

The D9000 should be attached to the vehicle chassis via two sections of channel (minimum 4" x 2" or 100 mm x 50 mm). The D9000 machine and bracket assembly can then be bolted to these channels using 8 off M12 bolts and lock nuts.

The axis of the D9000 must be parallel to the vehicle PTO shaft (see figure 5) this can be achieved by angling the channel. This may result in the D9000 unit being visually out of alignment with the vehicle chassis.

VEHICLE CHASSIS

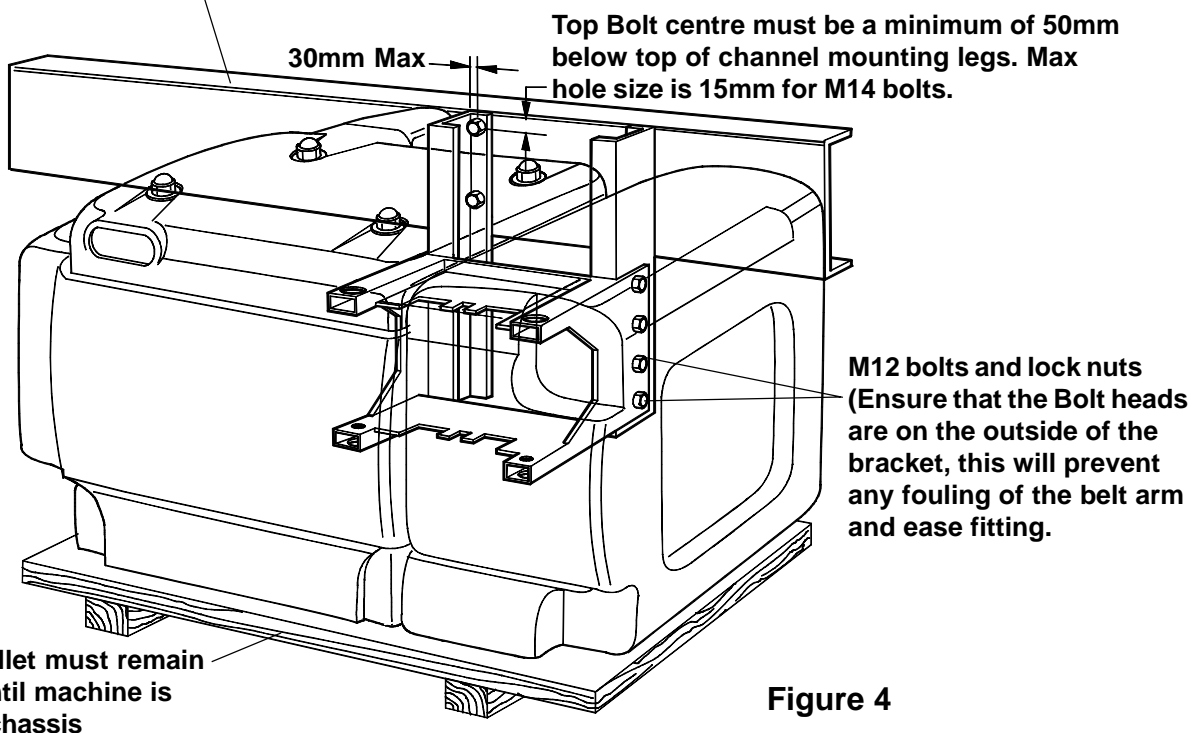
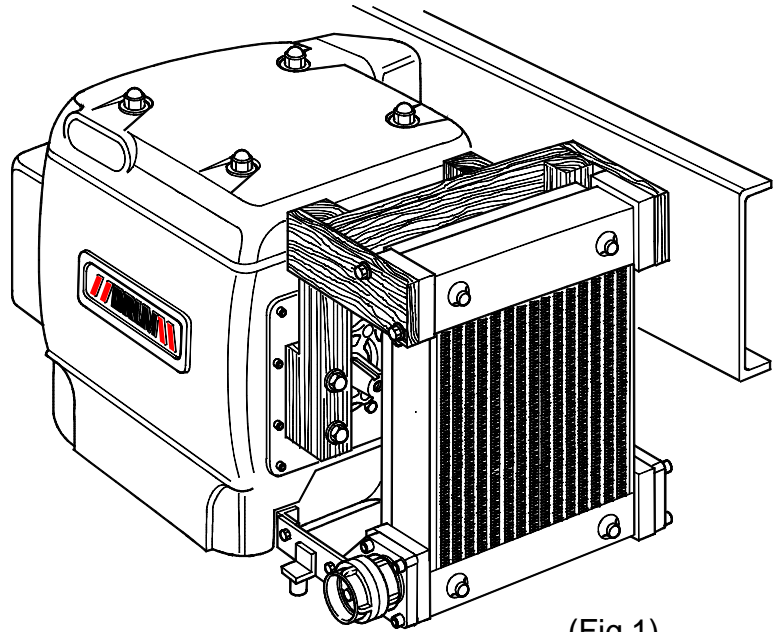

Figure 4

3.3 D9000 Cooler Radiator Mounting Instructions

The 'Cooler Ready' D9000 is shipped from Drum International with the radiator supported by a temporary transit bracket. This bracket holds the radiator in the correct position whilst the compressor is being installed on to a vehicle chassis. (Fig 1)

Note: It is the responsibility of the installer to ensure that all work carried out to fit the compressor, complies with the chassis manufacturers regulations.



(Fig 1)

After the compressor has been fitted and secured to the chassis, the radiator support bracket should be fabricated and drilled to suit the attachment points as shown in the radiator mounting diagram, (Page 5), then bolted to the chassis using 4 x M12 bolts and nuts.

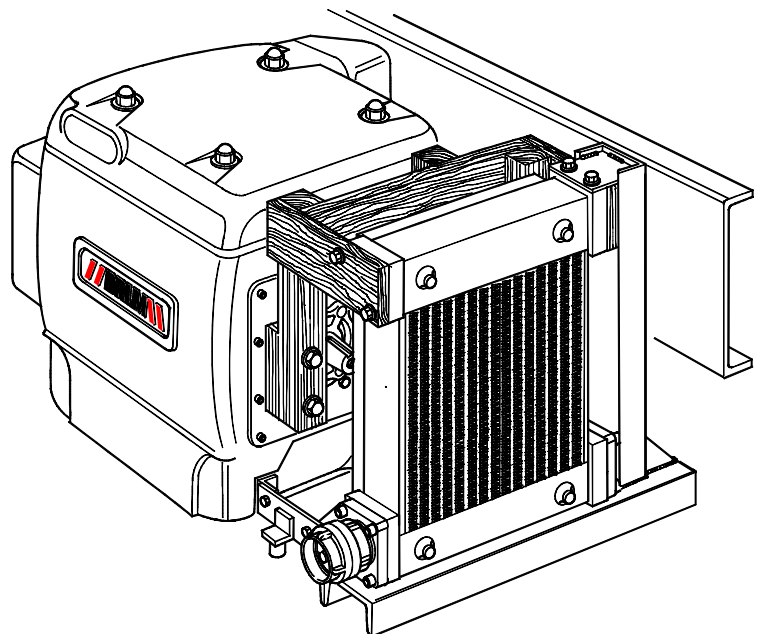

(Fig 2)

Remove the radiator and transit bracket (the bracket is discarded) then install the belt drive assembly, pulley and fan.

Refit the radiator and check concentricity of fan and fan cowl. If required the fan cowl can be adjusted by loosening its securing screws and repositioning as necessary (Fig 3) to give a constant clearance between cowl and fan blade tips.

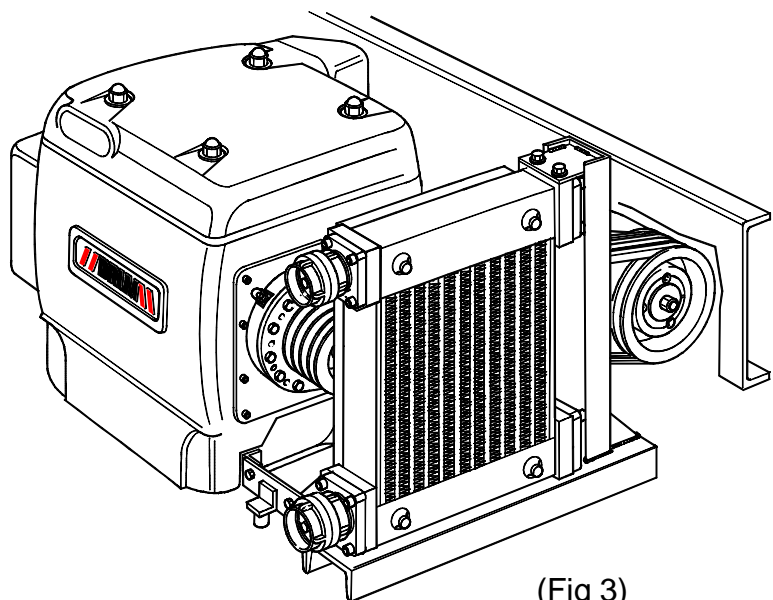

(Fig 3)

3.4 Drive Shaft Alignment

The D900 input drive and the vehicle Power Take Off (PTO) should be parallel within 1 degree and positioned such that the linking drive shaft makes an angle of no greater than 12 degrees.

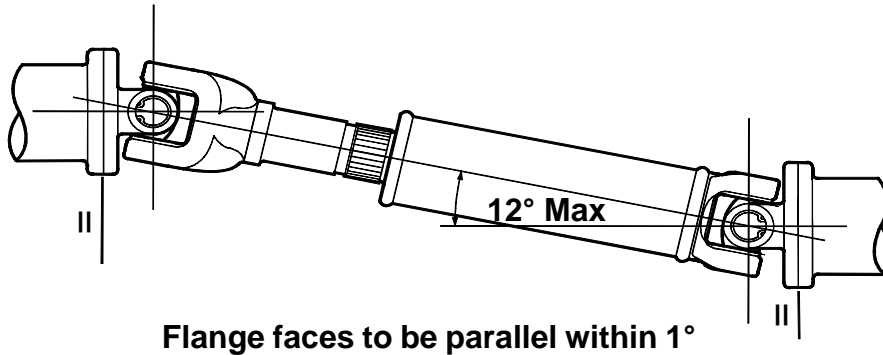

Fig 5

3.5 Belt Drive.

The D9000 unit is designed to be belt driven from the vehicle PTO. A belt drive unit suitable for the installation and capable of transmitting the required power can be ordered via your Drum dealer. Figure 6 shows the components of a typical Drum belt drive unit. The belt drive can be fitted to either of the two shafts on D9000 but the direction of rotation of the D9000 unit must be maintained (**see section 2.4**).

When ordering the belt drive the following information will be required:-

- The centre distance between the D9000 driven shaft and the PTO driver shaft.
- The angle of inclination of the belt drive to the horizontal. Note: For outboard drives the maximum recommended angle is 12°
- Required step-up ratio (standard is 1.78 : 1).

Belt Drive Installation.

The Belt Arm Assembly must be fitted **AFTER** the D9000 unit has been fitted to the chassis and not whilst the Compressor is on its delivery pallet. The pallet is not designed to allow the lifting of both Compressor and Belt Arm Assembly.

Assemble the inner Arm (1), Outer Arm (2), Outer Bearing Housing (3), and spacer (6) onto the D9000 compressor at the required side and angle of inclination. (Refer Fig 6, Page 10). Note: The driver pulley is factory fitted in a mid position and may need adjustment when checking the alignment of the pulleys.

Fit Driven Pulley onto D9000 Drive Shaft using Shaft Key and lock onto the drive shaft using the stud, securing nut and washer.

Loosen M10 setscrews (4) clamping the outer arm to the inner arm, slide the outer arm so the centre distance between the compressor and the bearing housing shafts is at a minimum. Re-tighten any two of the setscrews to hold this position.

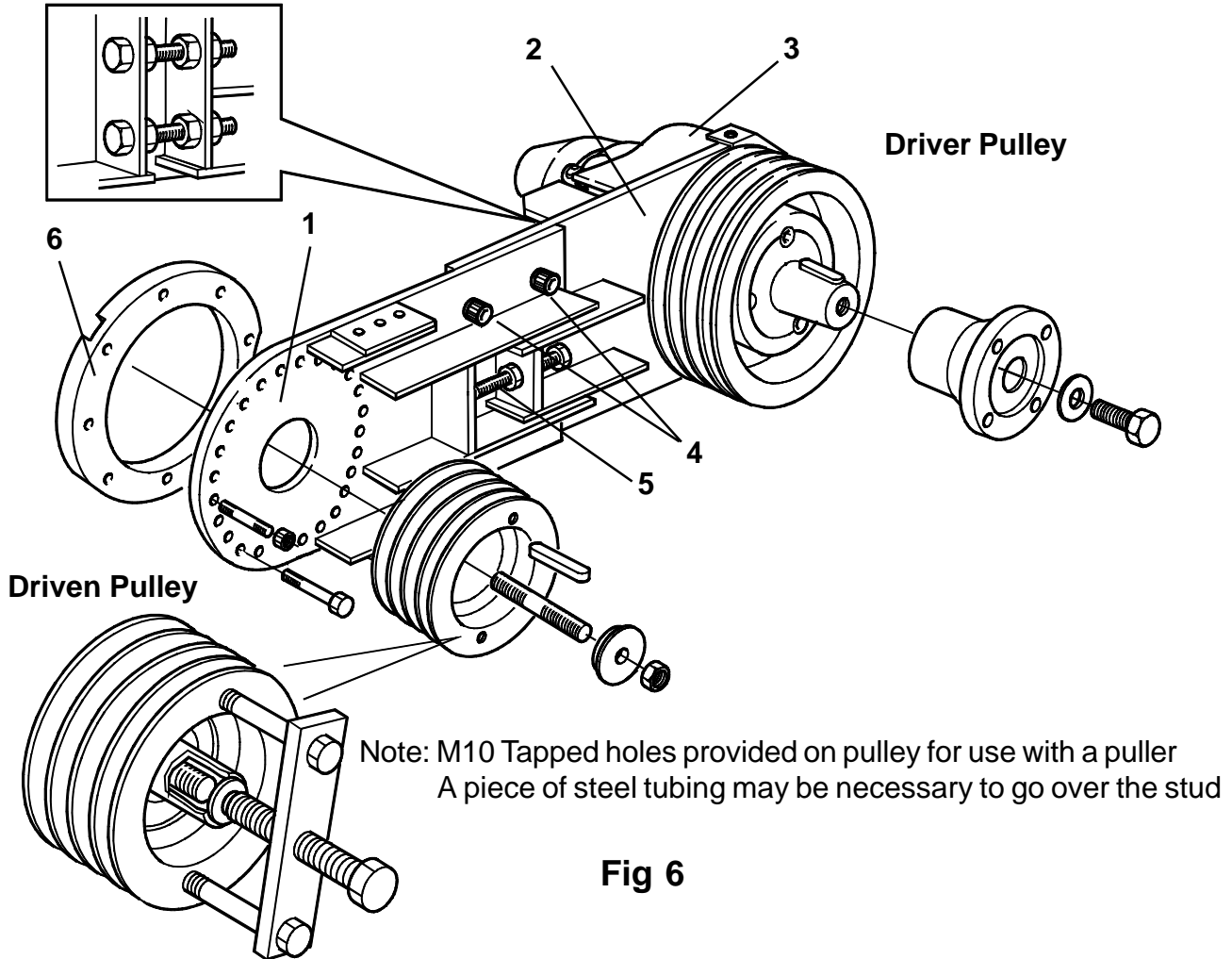

Fig 6

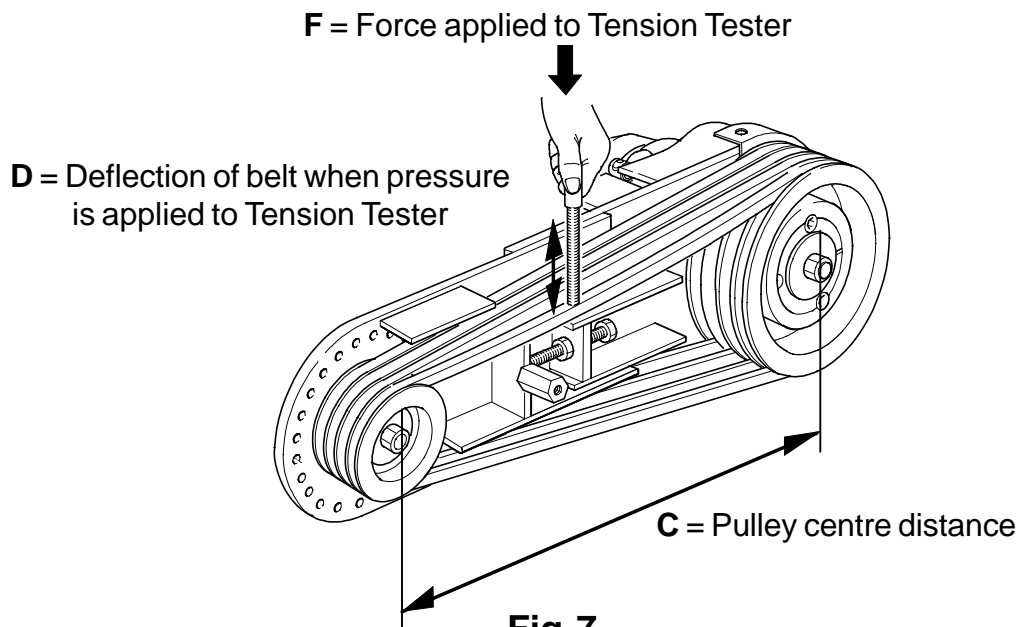

Fig 7

BELT TENSION VALUES							
C	mm	567	667	702	767	782	812
D	mm	5.6	6.7	7.0	7.6	7.8	8.1
F	N	40	40	40	40	40	40
	Kg	4.1	4.1	4.1	4.1	4.1	4.1
	Lbf	9	9	9	9	9	9

Fit the wedge-belts over the pulleys, loosen the two M10 setscrews which were tightened, and slide the outer arm away from the compressor to take up any slackness in the belts.

Tighten all M10 capscrews (4) holding the outer arm to the inner arm to 40 Nm.

NOTE : The wedge-belts are not under tension at this stage. Use a straight edge check the parallelism of both shafts as follows:

Using the front face of the driver pulley as a base reference, place the straight edge so it sits flat against the full faces of the two pulleys. If the straight edge does not touch on both sides of each pulley, the shafts are not parallel.

Alter the bearing housing shaft to a parallel condition by adjusting the two M10 bolts behind the outer arm (inset fig 6) slightly bending the belt arm. Re-tighten to 52.5 Nm.

Re-check alignment until the compressor pulley touches the straight edge across the full face of each pulley. It may be necessary to re-align the Power Take Off end pulley by sliding it backwards or forwards on the shaft extension collar after loosening the taper lock bush.

Re-check the pulley alignment.

Re-adjust if necessary.

Tighten the tension belts as follows :

Loosen the M10 setscrews (4) clamping the inner arm to the outer arm and then tighten fingertight.

Using the M16 tensioning bolt (5), apply tension to the wedge-belts and using a belt tension indicator (Drum Part No. 648.20.00.000-2), apply the correct tension (**as shown in table fig 7**) at the mid-point of distance ("**C**") with force ("**F**") applied perpendicularly to the belt, which at the correct tension (**shown in Table fig 7**) should displace the belt by distance ("**D**")

Tighten the M10 setscrews holding the inner arm to the outer arm, to 40 Nm.

Re-check the alignment of the pulleys and if necessary, readjust the bolts behind the outer arm to bring the pulley faces back into alignment.

Re-check the belt tension and adjust if necessary.

Re-tension the wedge-belts after 30 minutes running time and check tightness of all fastenings.

.

3.6 DISCHARGE AIR COOLER.

The D9000 Discharge air cooler is fitted to reduce the temperature of the outlet air when dealing with heat sensitive products (plastic granules and sugar for example). The D9000 cooler is supplied in either Left Hand or Right Hand configuration (refer to Fig 3A). *Note: Illustrations below depict Right Hand installations.*

Belt Drive kits are supplied so that the cooler fan is always driven from the inboard drive shaft (Figs 8 and 9).

Drum can supply a suitable belt drive for most installations.

Note: Fans are 'Handed' and they must always have an airflow AWAY from the compressor and through the radiator.

Consult your Drum agent for appropriate drives.

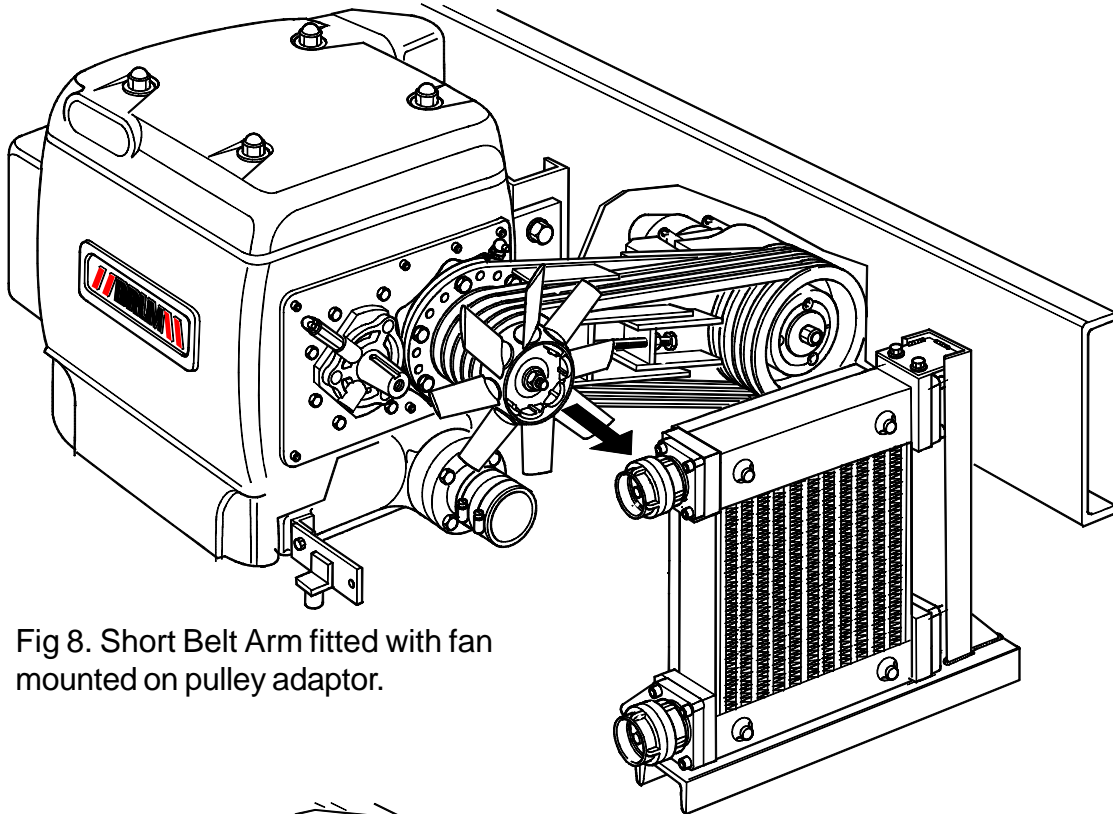

Fig 8. Short Belt Arm fitted with fan mounted on pulley adaptor.

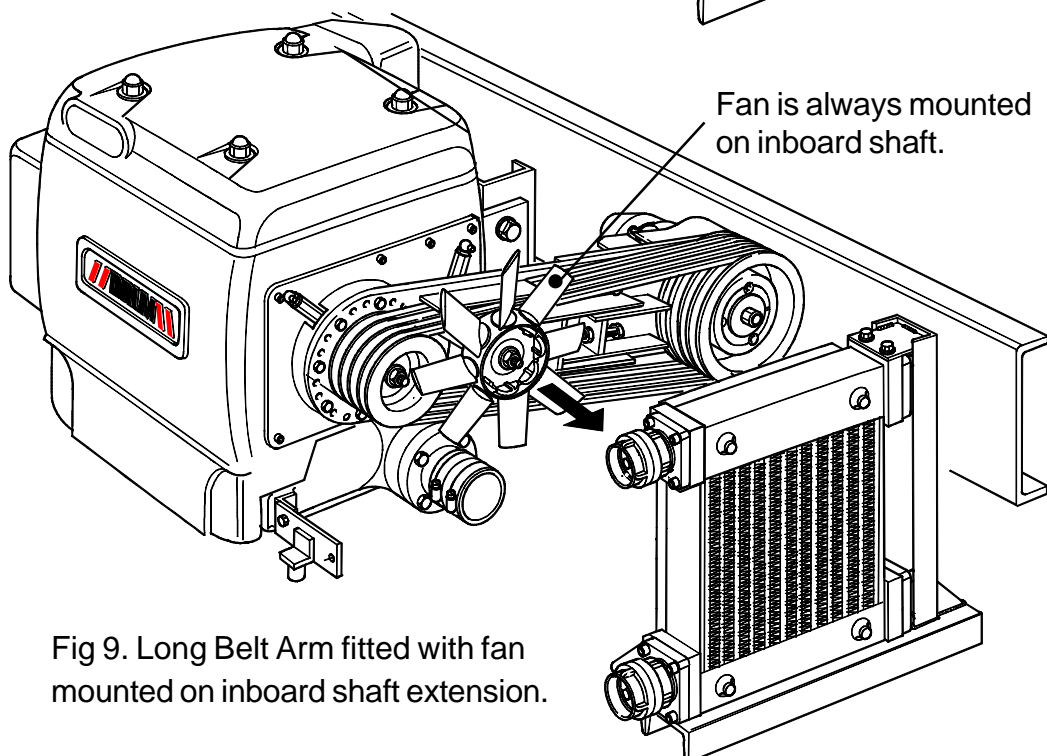
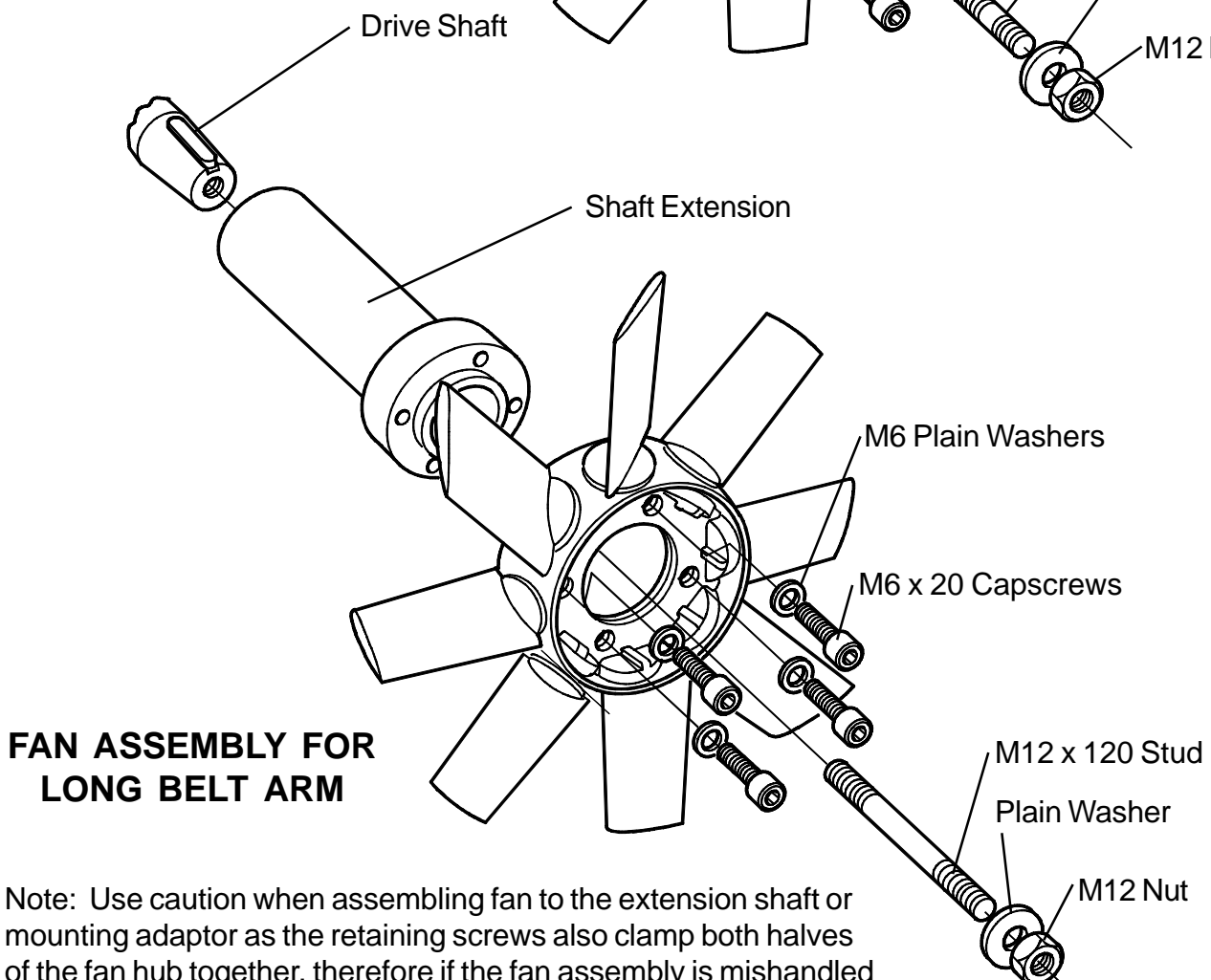
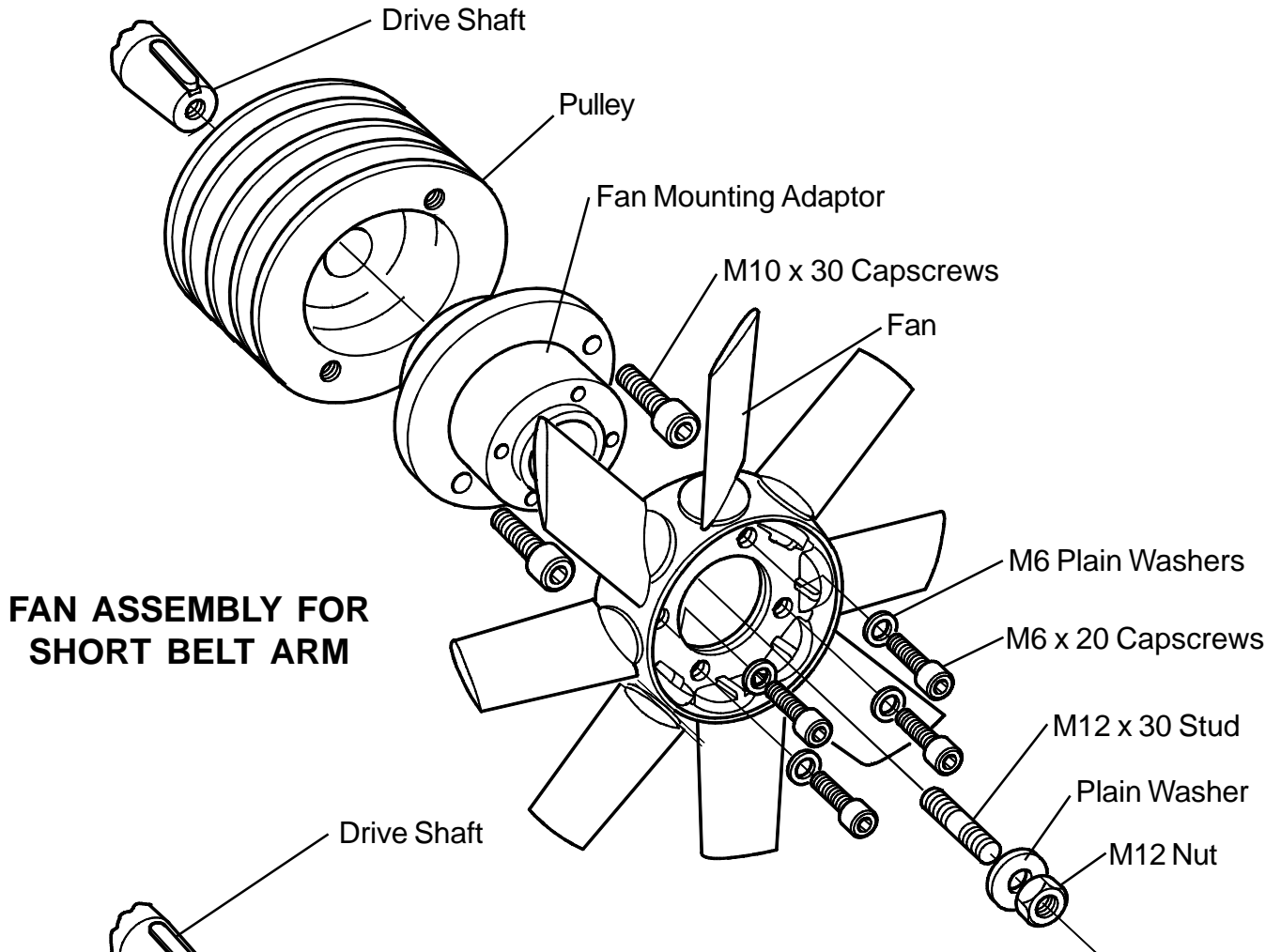

Fig 9. Long Belt Arm fitted with fan mounted on inboard shaft extension.

3.7 FAN MOUNTING ARRANGEMENT FOR SHORT AND LONG BELT ARMS.



Note: Use caution when assembling fan to the extension shaft or mounting adaptor as the retaining screws also clamp both halves of the fan hub together, therefore if the fan assembly is mishandled the blades could fall out.

3.8 REMOVING THE RADIATOR COVER.

If the radiator cover needs to be removed for servicing or checking the belt tension, remove the five M8 button head screws and spacers (A and B, Fig 10) and slide the cover outwards from the vehicle chassis.

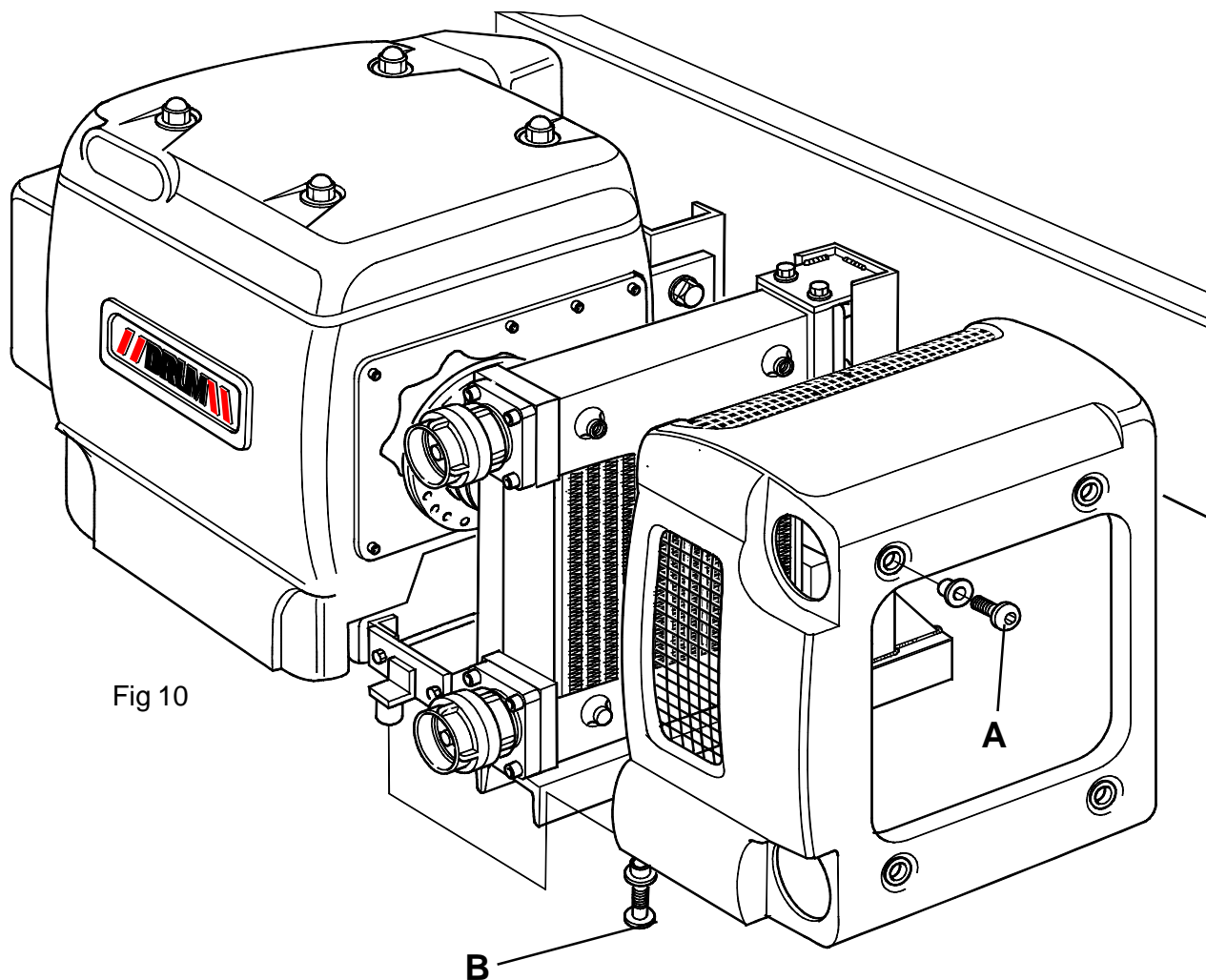

Fig 10

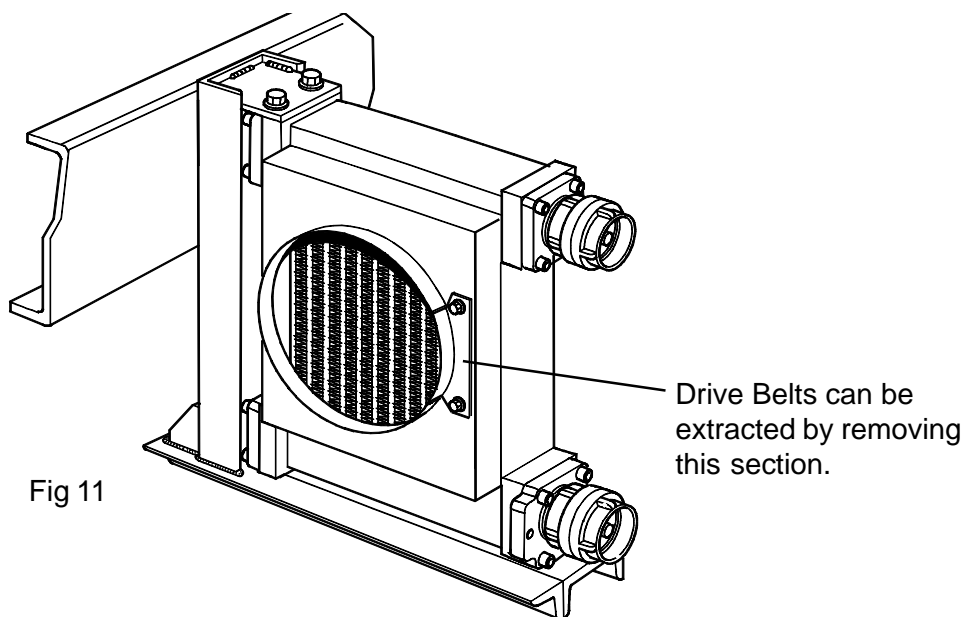

Fig 11

3.9 REMOVING THE DRIVE BELTS

If the drive belts have to be removed, a removable section is provided in the fan cowl to allow the belts to be pulled out around the fan blades.(Fig 11).

3.10 Ancillary Equipment.

3.10.1 Relief Valve.



The D9000 unit must never be operated without the integral relief valve.

The relief valve must be capable of venting the full flow of the compressor, at a maximum pressure of 2 bar g. (Please contact your Drum supplier for more information). The relief valve must be mounted to vent away from the operator. A warning label must be positioned adjacent to the discharge area, warning of the danger of burns caused by hot air venting. The relief valve must vent direct to atmosphere.

3.10.2 Integral Inlet air filter.

A pleated aluminium or paper type inlet air filter is fitted to the D9000 unit to prevent the ingress of any material that could damage the machine (Refer to page 13 for replacement details).

3.10.3 Check Valve.

A check valve is fitted into the outlet silencer discharge port to prevent reverse rotation of the unit which can be caused by pressurised air in the vehicle's tank.

3.10.4 Silencers.

An outlet silencer is integral with the unit and is situated underneath the compressor. An inlet silencer is built into the lid assembly.

3.10.5 Discharge filter (not supplied).

Drum can supply an inline micronic discharge filter (Rated at 5 microns) to remove contaminants in the discharged air. Filters of this type are essential for use with foodstuffs. When fitted, discharge filters should be fitted after any valves in the system.

3.10.6 Discharge pipework.

The discharge pipework can reach temperatures of 200 degrees Celsius. It is recommended that all discharge pipework be guarded and a warning label attached to warn the operator of the danger of burns. Combustible material must not come into contact with the discharge pipework. Where possible the discharge pipework should be isolated from direct transmission of vibration to the vehicle chassis.

4 OPERATING INSTRUCTIONS

4.1 Safety



To avoid the risk of burns, **do not touch pipework or stand next to venting valves**. If there is a risk for any reason we recommend the use of heat resistant gloves/clothing.



Where the operator will be subject to prolonged exposure to noise, it is recommended ear protection should be used.

For safe use, the maximum speed should not exceed 3000rpm and the maximum pressure should not exceed 2.0 bar gauge.

4.2 Starting the compressor.

Check that the Power Take Off is **disengaged** then start the engine.

NOTE : The D9000 should not be started against full discharge pressure. Depressurise by operating the pressure vent valve before starting the D9000 unit.

Set the engine speed to tick over.

Depress the clutch and allow a minimum of 5 seconds for the gears to stop rotating.

Engage the PTO.

SLOWLY release the clutch.

Check that the D9000 is producing air.

Set the engine speed to give a compressor operating speed between 1800 rpm and 3000 rpm as required.

NOTE : Avoid starting and stopping the compressor against pressure.
Return engine speed to tick over before disengaging the PTO.

5 MAINTENANCE INSTRUCTIONS

5.1 Routine Maintenance

The service intervals stated below are based upon intermittent usage of the D9000 unit, with total operating time of less than 5 hours/ day. For continuous operation, or operation at high temperatures, a more frequent and more rigorous service schedule is required. Consult your Drum distributor for details.

- | | | |
|-----------|---|--|
| Monthly | - | Inspect Air Filters.
Check oil Level in Gearcase. (Page 17)
Check security of mounting bolts.
Check Drive Belt tension. (Page 11) |
| 3 Monthly | - | Check Relief Valve operation. (Page 18) |
| 6 Monthly | - | Inspect Inlet Air Filter, Clean or replace if necessary. (Page 17) |
| Yearly | - | Replace Air Filter. (Page 17)
Change Gearcase oil. (Page 17)
Grease Bearing Housing Caps. (Page 18) |

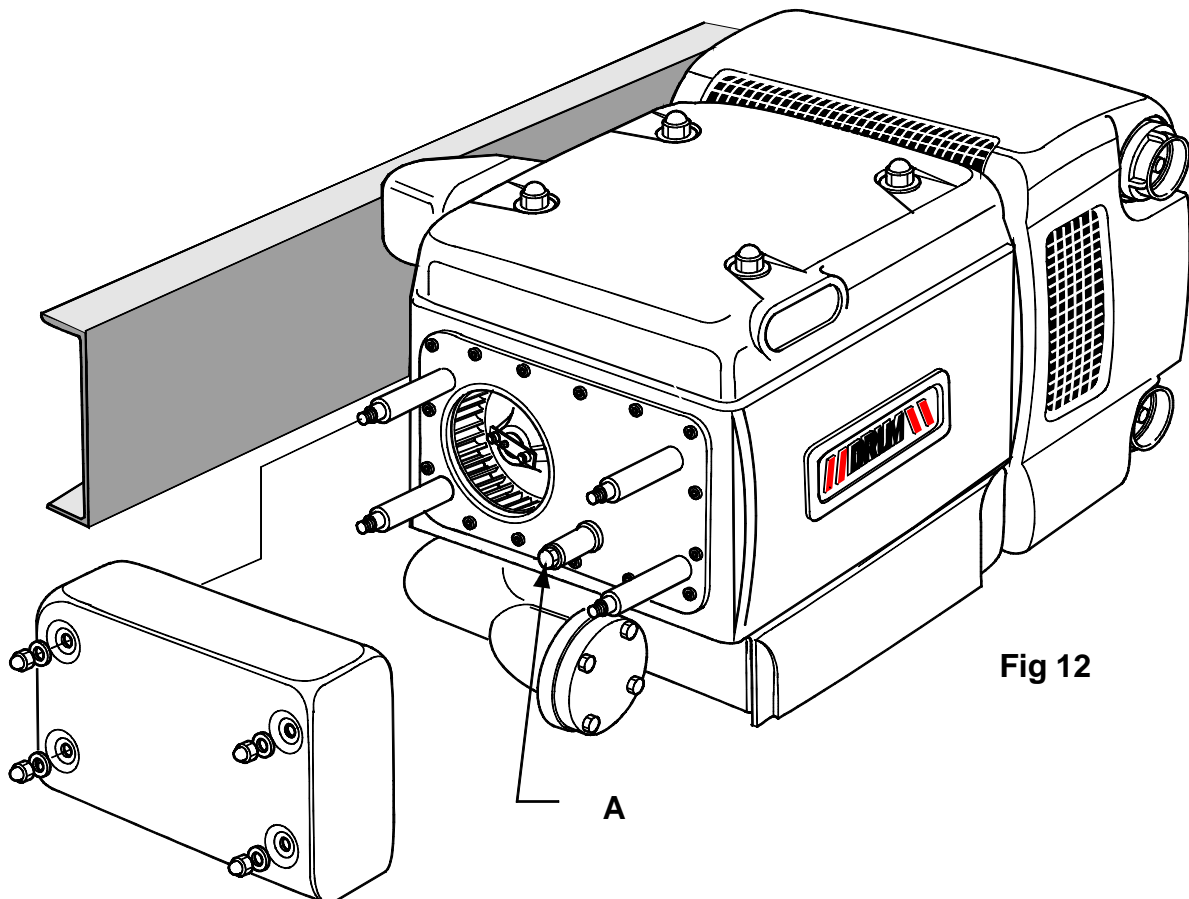

Fig 12

5.2 Draining the Gearcase Oil

To drain the gearcase Oil:-

Remove the GRP cover by removing the four dome nuts and washers. (Fig 8) and withdraw the cover sideways away from the chassis rail.

Remove the 3/8" B.S.P. plug (Item 'A', Fig 8) and washer and drain the oil into a suitable container.

5.3 Refilling and checking the oil level

To change the oil first drain the machine as described in section 5.2 then remove the 4 dome nuts and washers securing the top GRP cover. Remove the combined oil filler/dipstick and pour approx 1.75 litres of replacement oil (Refer chart below for recommended oils) through the oil filler tube. Check oil level after allowing to settle, do not allow oil level to be above the maximum mark on the dipstick.(Fig 9)

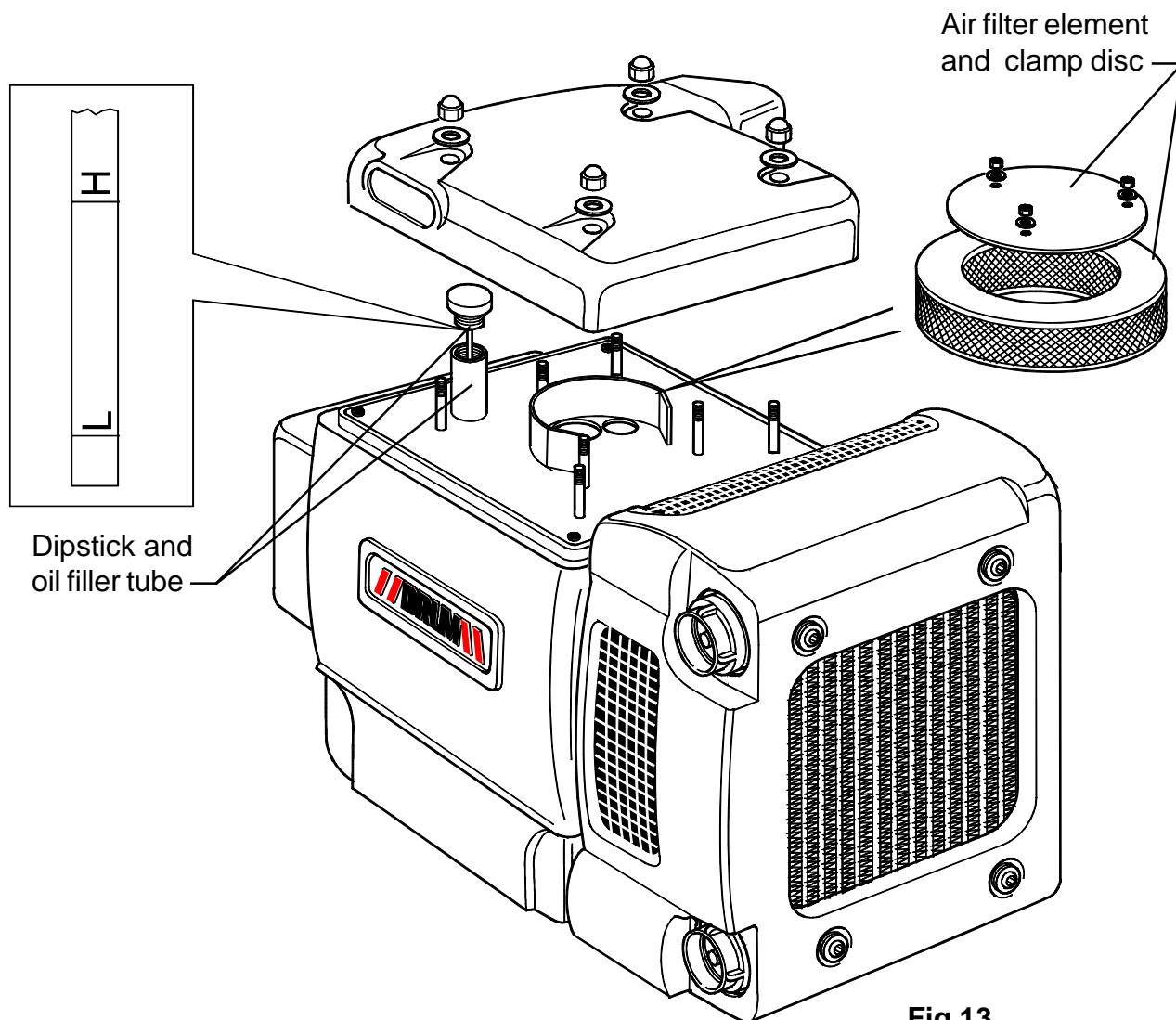

Fig 13

RECOMMENDED OILS

Gearbox oil suitability chart - Gearbox capacity 1.75 litres - ISO 220 (SAE 90) Synthetic oil

BURMAH CASTROL ALPHASYN T220	ELF OIL REDUCTELF SYNTHESE 220	SHELL OILS SHELL TIVELA WB	MOBIL OILS GLYGOYLE 30
---	---	---	---

5.4 Changing the Air Filter

To change the Air Filter, remove the top GRP cover and Filter Clamp Disk (Fig 9). The element can then be lifted out and replaced. Paper elements (Part No. 6289992000-2) should be changed every 6 months.

Pleated aluminium elements (Part No 6289892000-2) should be inspected every 6 months and any blockage can be blown out with a compressed air line.

IMPORTANT: When the element has been removed, ensure that nothing can fall into the machine through the inlet port.

5.5 Checking Relief Valve Operation.

A relief valve is mounted on the silencer and its operation should be checked at regular intervals. This can be achieved by the following procedure:

- Fit a gate valve and pressure gauge into the discharge air pipework downstream of the relief valve.
- Start the compressor with the gate valve open and bring the compressor up to speed. Slowly close the gate valve and check that the pressure on the gauge does not exceed the pressure setting of the relief valve.
- When the 'crack' pressure is reached, close the gate valve completely and observe the reading on the gauge when the valve reaches full by-pass, (This reading should match the setting that is stamped on the hexagon at the base of the valve).
- If the reading exceeds 0.2 bar above the set pressure, the relief valve is defective, and the test procedure must be stopped immediately. The valve must be replaced before running the compressor again.

Slowly open the gate valve and stop the compressor.



This procedure should be carried out every three months to clear the valve seat and check the valve is functional. (Ear protection is recommended).

5.6 Greasing the Drive Shaft Bearing Caps

To grease the drive shaft bearing caps it will be necessary to remove the radiator GRP cover (Refer Fig 10, page 11) by unscrewing the 5 socket head screws. Two 'elbow' type grease nipples are located on extension shafts above the drive shafts / bearing caps (Fig 14). Drum recommends they are greased once a year or every 500 hours of operation, whichever is the sooner. When applying grease it is important to note that old grease followed by the new will be expelled past the shaft seals when bearing housings are full. Ensure that this excess grease is cleaned off to avoid contamination of the drive belts. Note: Illustration below shows radiator moved for clarity

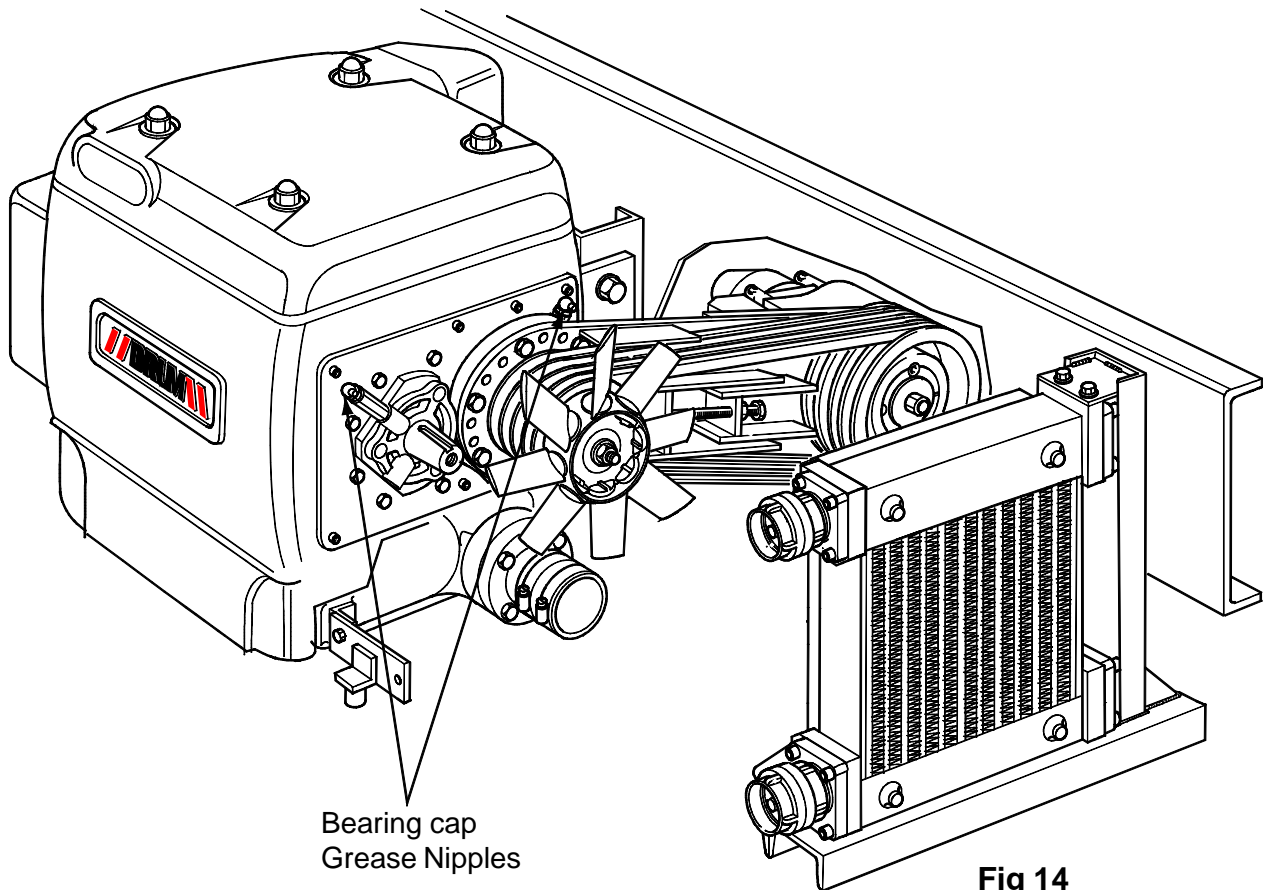

Contact Us

Americas

Gardner Denver, Inc.
Industrial Products Group - Americas
1800 Gardner Expressway
Quincy, IL. 62305
Toll Free: 1-800-682-9868
Phone: 217-222-5400
Fax: 217-221-8780

email: mobilesolutions@gardnerdenver.com

France

Gardner Denver France SA
Division Compresseurs
42, rue du Montmurier, BP 604
38070 Saint-Quentin-Fallavier, France
Phone: +33 (0)474941673
Fax: +33 (0)474941689

email: contact.lyon@gardnerdenver.com

UK Sales & Service

Gardner Denver UK Ltd
PO Box 468
Cross Lane, Tong
Bradford, West Yorkshire
United Kingdom
BD4 0SU
Phone: +44 (0)1274 683131
Fax: +44 (0)1274 651006

email: sales.uk@gardnerdenver.com

Australia

Gardner Denver Ind. Australia Pty Ltd
30 Bearing Road
Seven Hills
New South Wales
2147 Australia
Phone: +61 2 96207000
Fax: +61 2 96207955

email: hermant.malik@gardnerdenver.com

Germany

Gardner Denver Deutschland GmbH
Am Dorn 14
48308 Senden
Germany
Phone: +49 (0)253634840
Fax: +49 (0)25363484010

email: info.de@gardnerdenver.com

Spain

Gardner Denver Iberica S.L.
Calle Primavera, 20
Poligono Industrial Las Monjas
28850 Torrejon de Ardoz
Madrid, Spain
Phone: +34 (0)916560056
Fax: +34 (0)916770496

email: aurelio.fernandez@gardnerdenver.com

Belgium

Gardner Denver Belgium N.V.
Luithagen 7A
Haven 200
B-2030 Antwerpen
Belgium
Phone: +32 (0)3 5415040
Fax: +32 (0)3 5416509

email: info.be@gardnerdenver.com

Netherlands

Gardner Denver Nederland BV
Barwoutswaarder 3B
3449 He Woerden
The Netherlands
Phone: +31 (0)348410150
Fax: +31 (0)348418079

email: sales.nl@gardnerdenver.com

Rest of the World

Gardner Denver Ltd
PO Box 178
Springmill Street
Bradford, West Yorkshire
United Kingdom
BD5 7YH
Phone: +44 (0)1274 718100
Fax: +44 (0)1274 655272

email: gdtransportsales@gardnerdenver.com

For additional information, contact your local representative or

The logo for Gardner Denver, featuring the word "Gardner" in a large, bold, black sans-serif font above the word "Denver" in a similar font. A thick red horizontal line is positioned between the two words.

Gardner Denver Ltd
PO Box 178,
Springmill Street,
Bradford,
West Yorkshire, UK
BD5 7YH

Tel: +44 (0)1274 718100

Fax: +44 (0)1274 655272

Email: gdtransportsales@gardnerdenver.com

Web: www.gd-transport.com