

P2620 Liquid Ring Vacuum Pumps and Compressors

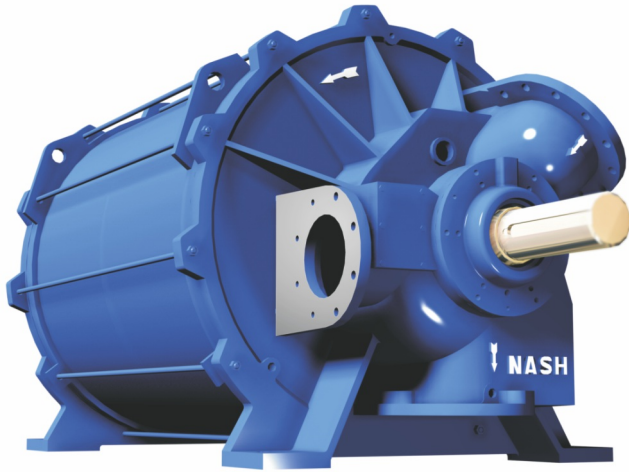

Designed to operate in demanding environments such as paper, power, mining and chemical process industries, this pump combines durability and reliability with low operating costs. The P2620 has a polyisoprene-lined body for corrosion and erosion resistance. This is a standard feature.

The unique inlet configuration allows for both top and side inlet arrangements to accommodate low headroom installations. Bottom and side discharge connections offer flexibility to address installation space constraints.

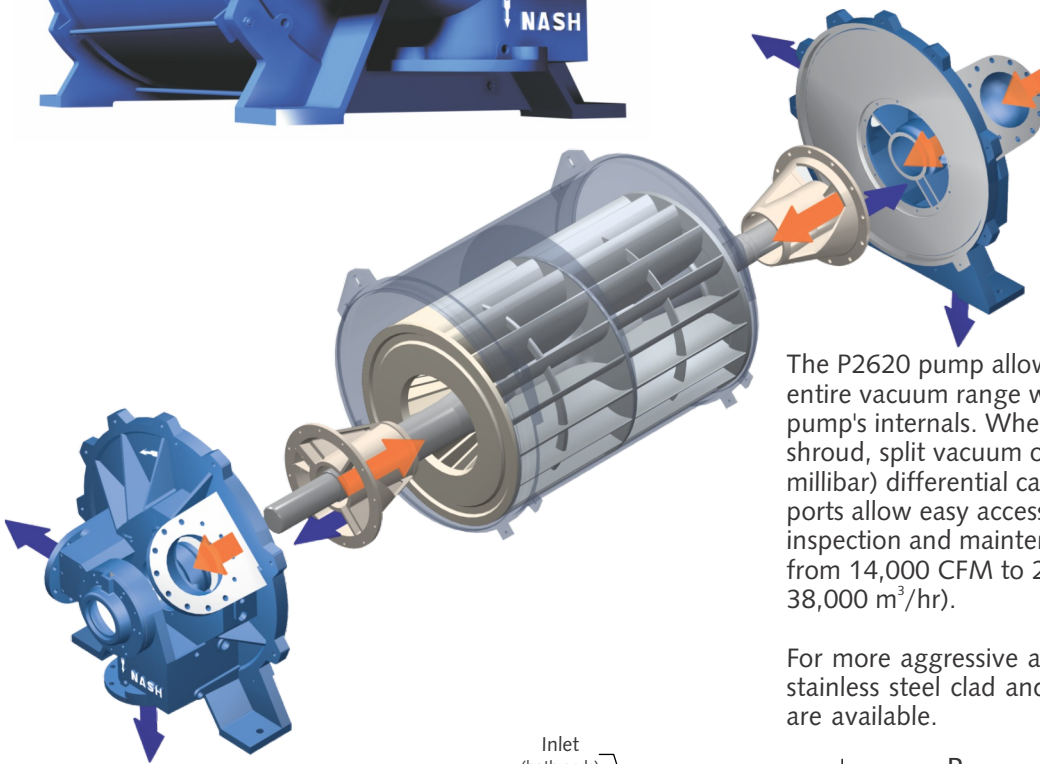

The P2620 pump allows efficient operation over the entire vacuum range without the need to change the pump's internals. When equipped with a center shroud, split vacuum operation up to 10 in. Hg (340 millibar) differential can be achieved. Large inspection ports allow easy access to pump internals for inspection and maintenance. Performance ranges from 14,000 CFM to 22,000 CFM (24,000 m³/hr to 38,000 m³/hr).

For more aggressive applications, stainless steel, stainless steel clad and epoxy coated components are available.

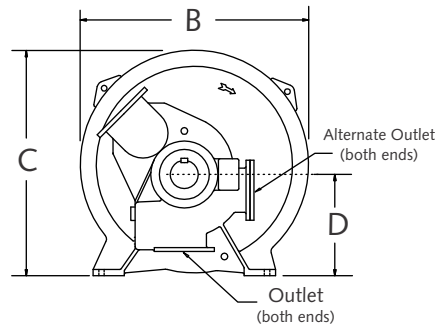
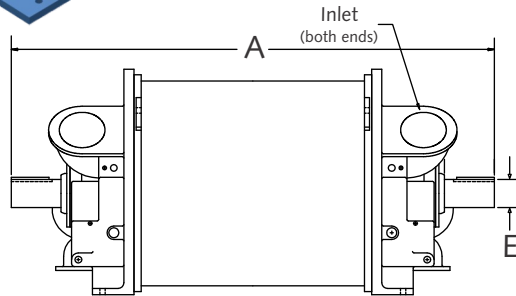

Dimensions mm in blue

Pump	A	B	C	D	E	Inlet	Outlet
P-2620	169 4293	80 2032	79 2007	35.5 902	9.8 249	16 in. FLG. 400mm FLG.	14 in. FLG. 350mm FLG.

All dimensions are approximate

NASH - Division of Gardner Denver

phone: +1 800 553 NASH · +1 724 239 1500 · fax: +1 724 239 1503 · email: nash@gardnerdenver.com

GDNash.com